



Operational and Maintenance Manual

Visionvent

Contents

Section Description	Page
Introduction	3
Safety Information	4
Electric Visionvent Controls and Operation	6
Electric Visionvent Manual Override	9
Electric Visionvent Troubleshooting	12
Chain Actuated Visionvent Controls and Operation	14
Chain Actuated Visionvent Manual Override	15
Chain Actuated Visionvent Troubleshooting	16
Manual Crank Visionvent Operation	17
Manual Crank Visionvent Manual Override	17
Glass Specification and Breakage Instructions	18
Routine Testing and Maintenance	18
Disposal at End of Life	20
Security and Certification	20
Serial Number	21
Warranty Information	21
Maintenance Log	22

Introduction

Thank you for purchasing a Glazing Vision Visionvent. We hope that it gives you many years of service. Available in electric, chain actuated and manual crank versions, the Visionvent is an opening product designed to provide ventilation. The product can be opened to a maximum height of approximately 320 mm (varies depending on product type).

The product is intended to provide natural daylight, day-to-day ventilation and weather resistance. It is not suitable for use as access.

A variety of optional extras including a rain sensor, thermostat, remote control, Building Management System connectivity and easy clean coating are available.

This product is robust and long-lasting, boasting excellent thermal performance, air tightness and reliable operation.





Servicing and maintenance must only be carried out by suitably qualified personnel. Care should be taken when working on the product, avoiding accidental damage and ensuring operational reliability. The mechanisms are very powerful, **at no time should hands or arms work through the mechanisms, always work around them.** Maintenance requirements can be found within this manual and maintenance log records must be completed to ensure the unit performs as required and the warranty is not invalidated.

Should you have any queries beyond this manual please do not hesitate to contact Glazing Vision.



Safety Information

Accessing your rooflight in order to carry out routine maintenance may involve working at heights, working at an unusual angle, being in unfamiliar locations or all of these. **Before** work is commenced, stop and consider the best way to carry out the task and what hazards you might encounter.

	<p>Let our experts carry out your routine maintenance with a maintenance contract. Contact: www.glazingvision.com/contact</p>
	<p>Consider:</p> <ul style="list-style-type: none"> • How you will safely access your rooflight to carry out maintenance. • Any openings, voids or unprotected edges that might pose a significant risk whilst working at height. • Using an elevated platform, cherry picker or scaffolding in preference to a ladder. • If specialist access is needed. • What personal protective safety equipment is required. • How you will transport equipment to the rooflight. • How you will work so as not to drop equipment. • Your personal capability to safely carry out the task. • Wearing suitable clothing so as not to snag or catch on things. • Impact of weather on the task, especially driving rain and high winds. <p>If in doubt, please contact Glazing Vision for assistance.</p>
	<p>Anticipated hazards may include:</p> <ul style="list-style-type: none"> • Falls from height. • Unsafe use of ladders. • Equipment falling from height. • Slips, trips and falls. • Fragile roof areas. • Finger or clothing entrapment in mechanical or moving parts. • Working with electricity.
	<p>Do not attempt to repair, move or dismantle the product unless suitably competent and qualified to do so, with the appropriate safety measures in place. Any repairs and/or movement of the product may invalidate the warranty. Please seek advice from Glazing Vision.</p>
	<p>Any electrical work is to be carried out by a qualified and competent electrician in accordance with Glazing Vision's wiring diagram(s).</p>

 **Warning**

The following warnings are here to prevent personal injury and damage to the product. Please follow them explicitly.

- The product must be properly installed and commissioned in accordance with the installation manual before it is used.
- Use the product only for its intended purpose.
- Regular cleaning and maintenance must be carried out according to the guidelines described in this manual.

-
- Glazing Vision strongly recommends that any work is carried out by suitably qualified individuals (e.g. Glazing Vision trained personnel or contractors, or an experienced electro-mechanical service engineer).
 - Do not touch the motors/mechanisms after operating the product as they may become hot.
 - Do not walk or sit on the unit.
 - Risk of crush and/or trapping injuries. Make sure that fingers and other obstructions are kept clear of the product and its mechanisms at all times.
 - Overcurrent protection is designed to prevent damage to the product and its mechanisms. It should not be relied upon to prevent injuries.
 - Do not place anything on, or cause obstruction to, the moving sections of the product as this may cause damage to the mechanisms/product and/or prevent the unit from opening/closing.
 - Do not allow unauthorised persons (e.g. children) to operate the product as this may lead to personal injury or damage to the product. Do not leave children or pets unsupervised near the product – it may open/close unexpectedly (e.g. due to the rain sensor activating) and cause injury.
 - Do not pull on the cables where they exit the product. Doing so may loosen connections, result in damage to the product and/or create the need for a repair visit.
 - Do not leave the product open in the rain, this could damage the control board and/or mechanisms. If required, a rain sensor can be specified at the time of order.
 - Should any cables or electrical components break or become damaged, have them repaired or replaced immediately. Deteriorated insulation of electrical parts or overloading may cause an electric shock or fire.

For more information or assistance please contact Glazing Vision.

Electric Visionvent Controls and Operation

Various options are available at time of order. If specific data is required for your product, please refer to your order confirmation or contact your supplier for assistance.

Control Switch

The standard operation of the unit is via the supplied wall mounted control switch and can be operated using two different methods as explained below:

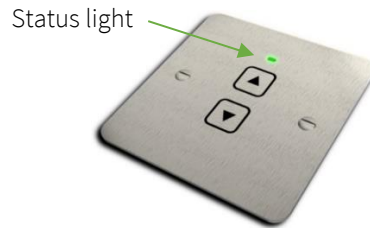

Figure 1 – Wall mounted control switch

‘One touch’ operation – A press of up to 5 seconds will be interpreted as one touch. Press and release the control switch once in either the up or down direction - the product will open or close fully. Partially open positions can be achieved by pressing the control switch again at any point during the open or close cycle.

Conventional ‘hold’ operation – Press and hold the control switch until the product has reached the desired position. Releasing the switch stops the product in that position (as long as the control switch has been pressed for more than the 5 seconds recognised as ‘one touch’ operation). Note that the product will stop automatically when it becomes either fully open or closed.



Do not leave your product open in rain or inclement weather. Glazing Vision cannot be held responsible for damage caused by failure to comply with this instruction.

Status Light

The status light will illuminate green if the product is functioning normally. If the status light displays another colour, please refer to the troubleshooting section of this document.

Remote Control (Optional)

The remote control unit functions in the same way as the wall mounted control switch but allows you to open and close your product from a short range. It has 3 control buttons, open, stop and close - the stop button can be used for partial opening.

The remote control is powered by 2 x AAA batteries. In order to preserve the batteries, the remote control will switch itself off after a brief period of inactivity. It will switch itself on when any of the buttons on the remote control are pressed. To replace the batteries, remove the small hex screws found on the rear of the remote to allow access inside. Note the polarity when inserting the new batteries.

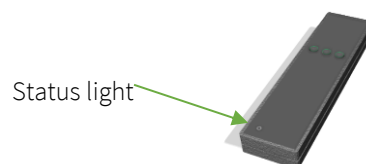

Figure 2 – Remote control

Pairing a Remote Control

Additional remote controls can be paired to or unpaired from the product. To put the product into pairing mode and prepare it for adding or removing a remote control follow these steps:

1. Ensure that the product is fully closed.
2. Press and hold the CLOSE (down arrow) button on the wall-mounted control switch.
3. Still holding the CLOSE button, press and hold the OPEN (up arrow) button.
4. As soon as the status light starts flashing, release both buttons.

The control switch status light will now flash red and blue alternately for 2 minutes. You now have a 2 minute window in which to pair the remote to the product.

To Add a Remote

Press any of the buttons on the remote control during the 2 minute pairing window. Wait for approximately 30 seconds and then press either the open or close buttons (this needs to be done before the 2 minutes are up). The remote control should now be paired to the product. When using the remote control its status light will illuminate green when the product is in motion.

To Delete a Remote

Ensure there has been at least 2 minutes since either the product was first powered up or from when the pairing procedure was initiated (i.e. you are not in the 2 minute pairing window). Press all three buttons on the remote control together and immediately release them. The status light on the remote control should turn red for a few seconds and then turn off. If it turns green or amber, try pressing the three buttons again. When the red status light turns off, the remote will be unpaired from the product.

Rain Sensor (Optional)

The rain sensor automatically closes the product when moisture is detected. When the product is opened it activates the built-in low power heater to evaporate any surface moisture (this will remove condensation/dew but not large amounts of standing water or ice). If moisture is still detected, the product will close on the assumption that it is raining (the status light will illuminate green). The control switch status light will also flash intermittent green indicating a closure due to rain. The rain sensor should be positioned horizontally (in line with the ground) in a location that will ensure that it is exposed to the rain and must be kept clean to function correctly.



Figure 3 – Rain sensor

Thermostat (Optional)

The thermostat offers control of the product to regulate the temperature within the building. For security reasons, when the property is unoccupied, the thermostat should be switched off and the product closed.

Battery Backup (Optional)

The ELMDENE Battery Backup Power Supply is a regulated 27.6V DC output, which is capable of supplying a total of 10 Amps continuously into the load, whilst also enabling battery charging. The power supply output features electronic short circuit protection under both mains and standby operation. Two 17Ah batteries (in series to provide 24V DC) allow full operation of the product for a limited period in the event of a power failure. The battery backup will resume normal operation once mains supply is restored. **Product use should be kept to a minimum during mains failure to maintain battery efficiency.**



Figure 4 – Battery backup supply

When fitting a Battery Backup supply, it is important to fit a non-fused isolator switch on the DC output, as detailed in the wiring schematics.

Building Management System Integration (Optional)

The product can be connected to building management systems. Please contact Glazing Vision for further details if required.

Electric Visionvent Manual Override

In the unlikely event of failure of the Electric Visionvent, it may be necessary to manually override the product and disengage the mechanisms to allow you to open/close the lid. Before considering manually overriding the product, several likely issues should be ruled out first. Check that power is being supplied to the Electric Visionvent, also check for any obstructions around the mechanisms, and lastly check that the wall switch is not showing any errors (if so, see the troubleshooting section). If none of these suggestions resolve the issue, then the product can be manually overridden.

Stuck Open

If the Electric Visionvent is stuck in the open position and will not close electrically, the mechanisms can be removed to allow the lid to be closed manually. Manual override can be done from the inside.

Do not attempt to manually override the product without a safe working platform.

Before disconnecting the mechanisms, prop the lid open on either side using two lengths of timber (it is important to use softwood to avoid damage to the aluminium extrusion). This will prevent the lid from falling when the mechanisms are disengaged. When working take care not to knock the supports out of place.

The override holes are located on the inside of the unit approximately 310 mm from the opening edge. Remove the cover caps to reveal the override pin (seen through the holes).

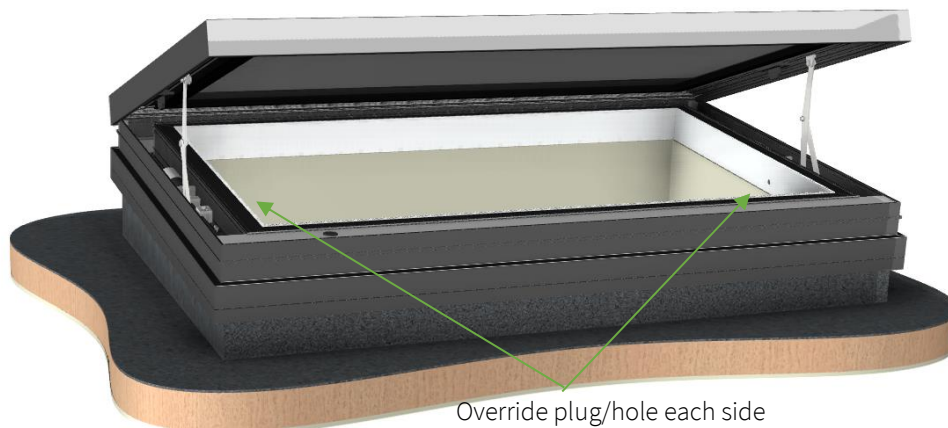

Figure 5 – Manual override location

Insert a 5 mm Allen key (supplied with the product) through the hole and engage with the cap head override pin. Support the weight of the lid and unscrew the bolts by turning anti-clockwise. Once both override bolts have been removed the main link arm will be free to move within the product's slide channel. The lid will be free to close.

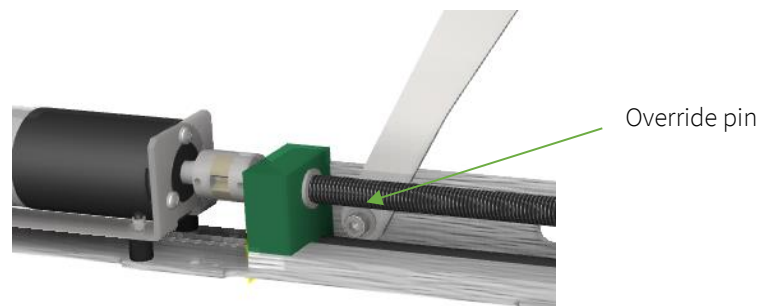

Figure 6 – Manual override bolt location

To remove the mechanisms completely, they must be disconnected from the lid. Located at the end of each link arm is a hexagon head pivot pin screwed into the sliding shoe, these can then be unscrewed using a 13 mm spanner to free the lid.

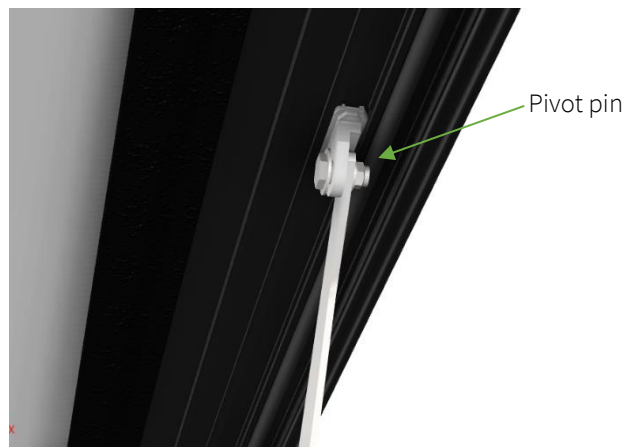

Figure 7 – Manual disconnect

With the lid no longer supported by the mechanisms, the weight of the lid can be supported manually allowing the timber supports to be removed. The lid can then be lowered closed slowly (take care – it will be heavy), ensuring not to damage anything. **Do not attempt to lift the lid without a safe working platform.** Do not open the lid past 90°, otherwise the lid will disengage from its extruded hinge and become detached from the base frame. Should this happen, the lid can be reattached by positioning it at approximately 95° to the base and slotting the two halves of the hinge together. The unit should now be watertight, but not secure.

Please contact Glazing Vision for further assistance – the product will no longer be operational. Once the issue is resolved, the product should be reassembled then re-initialised.

Stuck Closed

If the Electric Visionvent is stuck in the closed position and will not open electrically, the mechanisms can be disconnected to allow the lid to be opened manually. As the building will be watertight, manually overriding the Electric Visionvent from the closed position is best done when an engineer is on hand to resolve the issue. Manual override can be done from the inside. **Do not attempt to manually override the product without a safe working platform.**

Detach the mechanisms from the base following the steps in the previous section. Once disconnected, it will be possible to manually lift the lid open (take care - it will be heavy). **Do not attempt to lift the lid without a safe working platform.** Do not open the lid past 90°, otherwise the lid will disengage from its extruded hinge and become detached from the base frame. Should this happen, the lid can be reattached by positioning it at approximately 95° to the base and slotting the two halves of the hinge together.

Once the product is open, the mechanisms can be detached/reattached, and any problems can be diagnosed and resolved (contact Glazing Vision for assistance with this). Note that it may be necessary to prop the lid open using two lengths of timber (one either side of the product) so that it does not fall (it is important to use softwood to avoid damage to the aluminium extrusion). Any necessary work can now be carried out (when working take care not to knock the supports out of place).

Please contact Glazing Vision for further assistance – the product will no longer be operational. Once the issue is resolved, the product should be reassembled then re-initialised.

Re-Initialisation

If the manual override has been used the product may require re-initialising. Once mains power has been restored, re-initialise the product by pressing close on the control switch. The product is then ready to resume normal service.

If further assistance is required, contact Glazing Vision to arrange for an engineer to visit and resolve the issue.

Electric Visionvent Troubleshooting

The Electric Visionvent control board monitors the operation of the product. If a fault is detected, the control board will disable the unit to prevent possible damage. Fault and standard conditions are indicated by the status light on the control switch. The following table shows the various status light displays and their meanings.

Status Light Shown	Meaning
Continuous green	The product is moving as part of normal operation. If one touch opening/closing has been activated, the status light will remain lit until the product stops moving.
Intermittent green (flashes every second)	The product is closing but not under control of the operating switch or remote control e.g. due to an optional extra (such as a rain sensor) activating. The status light will continue flashing until the product stops moving.
Intermittent green (flashes once every 2 seconds)	The fire input connection (if specified) has been triggered. The status light will remain lit when opening to the fire position and when stationary afterwards so long as the fire input is still active.
Continuous blue	Indicates that the product has timed out (has taken too long to open/close). This is to avoid continuous operation of the motor(s) when there is a potential issue. So long as the cause has been rectified, pressing the open/close button will clear this condition.
Intermittent blue	Indicates an overcurrent or undercurrent condition (the current that the motor(s) are receiving is outside of the set limits). So long as the cause has been rectified, pressing the open/close button will clear this condition.
Continuous red (after power on/fault recovery)	Indicates that the product requires initialisation/synchronisation. Pressing close on the wall mounted switch will initiate synchronisation of the mechanism(s). The status light will flash red whilst this is in progress.
Intermittent red (after power on/fault recovery)	Indicates that the product is initialising/synchronising. The condition will clear automatically when the product has initialised.
Intermittent amber	An unrecoverable fault has been detected by the controller and product operation has been disabled. This state can be cleared by a button press combination (see table below) or removing power (including backup batteries) from the product.

If a fault occurs, please refer to the following table. Some faults with the unit may be easily corrected without the need for a site engineer to visit. Many faults can be cleared by resetting the board. To reset the system, switch off mains power briefly then switch the power back on again. Most faults should be cleared using this method, however, in the event the fault persists, please contact Glazing Vision for assistance.

Problem	Possible Cause	Action
Continuous blue Product has timed out.	The product has taken too long to open/close.	Check for possible obstructions or parts (e.g. sensors) that may have been knocked out of place. Once clear, press the open/close button.
Intermittent blue Overcurrent/undercurrent fault.	Something is preventing the mechanisms from opening/closing.	Check for and remove any obstructions to the mechanisms. Once clear, press the open/close button.
	The lid is frozen to the base.	Wait until the ice melts before attempting to operate the product.
	The product been left inactive for a long period (a month or longer).	This fault may occur after a long period of inactivity, reset the product (turn it off/on using the mains isolator switch) and try again.
Continuous red Synchronisation/initialisation state – the product needs to be initialised.	May occur after turning off/disconnecting the power when the mechanisms were not in the closed position.	Press the close button on the wall mounted control switch to initiate synchronisation of the mechanism(s). The status light will flash red whilst this is in progress.
Intermittent amber Fault lockout state – controller is unable to reset itself and the product has been disabled.	Cause unknown.	Do not attempt to recover this fault without being in full view of the product, ask for assistance. To force a resynchronisation, press both the up and down buttons of the wall mounted control switch at the same time for two seconds. The control switch status light will then toggle through red, green and blue colours, finishing with red. Press the down button to close the product and initiate synchronisation (the status light will flash red whilst this is in progress). If one of the mechanisms fails to move or if the fault is triggered for a second time, do not attempt to try again , and if required refer to the manual override instructions to close the product.
The product opens or closes for no apparent reason.	The rain sensor (if specified) is dirty or still wet triggering the product to close.	If it is raining wait until the rain stops before trying to open the product. If the rain sensor needs cleaning, open the product and isolate the power supply, then clean the rain sensor.
	The thermostat (if specified) is reacting to a change in temperature and triggering the product to operate.	Check that the thermostat is set to the desired temperature setting.
	The BMS system (if specified) is operating the product remotely.	Check that the BMS system is functioning correctly.
The rain sensor is not working.	The rain sensor is located in a position where it is shielded from the rain or the sensor is dirty.	Check the positioning of the rain sensor and move it to a more exposed position (a Glazing Vision engineer may be required for this task). If the rain sensor needs cleaning, open the product and isolate the power supply, then clean the rain sensor.

Chain Actuated Visionvent Controls and Operation

Control Switch

The standard operation is via the supplied wall switch and can be operated by pressing and holding the switch in the required direction to open or close. If the switch is released prior to the product reaching a fully open or closed position the product will stop. If the switch is held the product will stop when it is fully open or closed (at this point the switch can be released).



Figure 8 – Rocker switch

Rain Sensor and Thermostat (Optional)

The rain sensor will override the vent and automatically close the product in the event of rain. It also allows the Chain Actuated Visionvent to open automatically when ambient temperature exceeds your desired setting.

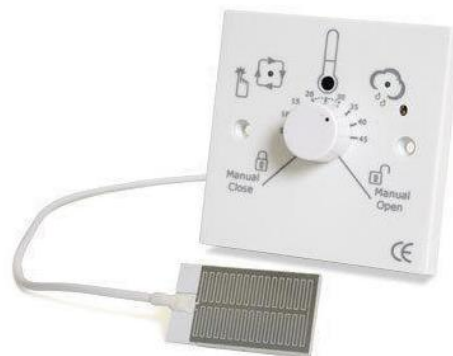

Figure 9 – Rain sensor and thermostat unit

Chain Actuated Visionvent Manual Override

In the unlikely event of failure of the Chain Actuated Visionvent, it may be necessary to manually override the product. Before considering manually overriding the product, several likely issues should be ruled out first. Check that power is being supplied to the Chain Actuated Visionvent, also check for any obstructions around the mechanisms. If none of these suggestions resolve the issue, then the product can be manually overridden.

Stuck Open

If the Chain Actuated Visionvent is stuck in the open position and will not close electrically, the mechanisms can be removed to allow the lid to be closed manually. Manual override can be done from the inside. **Do not attempt to manually override the product without a safe working platform.**

Before disconnecting the chain, prop the lid open on either side using two lengths of timber (it is important to use softwood to avoid damage to the aluminium extrusion). This will prevent the lid from falling when the mechanisms are disengaged. When working take care not to knock the supports out of place.

The pin that links the chain to the lid fixing bracket can then be removed by first removing the clip. Lower the chain down carefully, **do not let the chain drop** as this may damage the product. Do this for all chain actuators in the product.

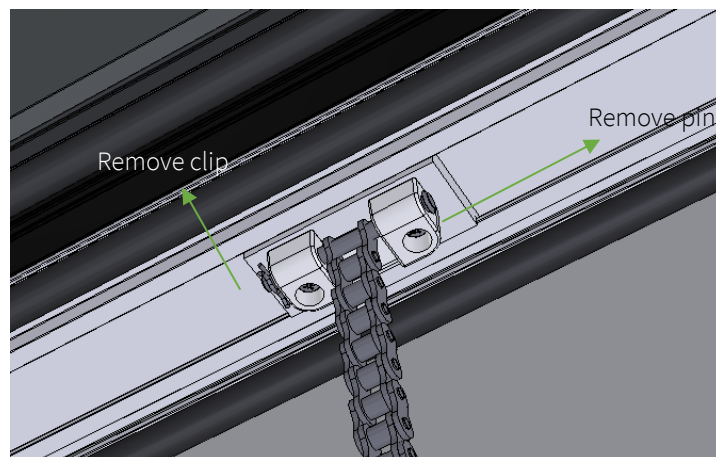

Figure 10 – Manual disconnect

With the lid no longer supported by the mechanisms, the weight of the lid can be supported manually allowing the timber supports to be removed. The lid can then be lowered closed slowly (take care – it will be heavy), ensuring not to damage anything. **Do not attempt to lift the lid without a safe working platform.** Do not open the lid past 350 mm as this may cause damage to the product. The unit should now be watertight, but not secure.

Please contact Glazing Vision for further assistance – the product will no longer be operational. Once the issue is resolved, the product should be reassembled then re-initialised.

Stuck Closed

If the Chain Actuated Visionvent is stuck in the closed position and will not open electrically, the mechanisms can be disconnected to allow the lid to be opened manually. As the building will be watertight, manually overriding the Chain Actuated Visionvent from the closed position is best done when an engineer is on hand to resolve the issue. Manual override can be done from the inside. **Do not attempt to manually override the product without a safe working platform.**

The override holes are located on the inside of the unit on the opening edge. Remove the cover caps to reveal the mechanism fixings (seen through the holes).

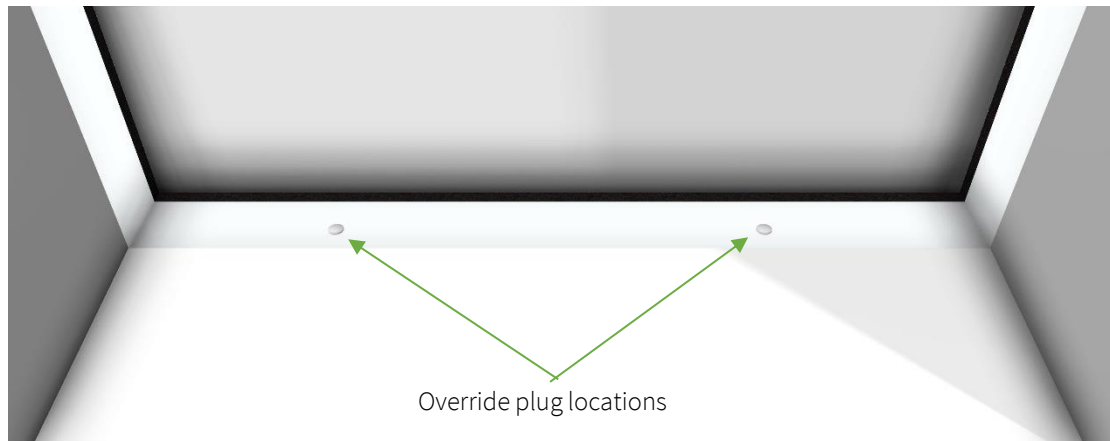

Figure 11 – Chain Actuated Visionvent override positions

Insert a 5 mm Allen key and rotate it anticlockwise to remove the fixings. Do this for all fixings present. This will free the chain actuator(s) from the base frame.

The lid can now be opened (take care – it will be heavy). **Do not attempt to lift the lid without a safe working platform.** Do not open the lid past 95°, otherwise the lid will disengage from its extruded hinge and become detached from the base frame. Should this happen, the lid can be reattached by positioning it at approximately 95° to the base and slotting the two halves of the hinge together. When closed, the unit should now be watertight, but not secure.

Once the product is open, the chain actuators can be detached/reattached, and any problems can be diagnosed and resolved (contact Glazing Vision for assistance with this). Note that it may be necessary to prop the lid open using two lengths of timber (one either side of the product) so that it does not fall (it is important to use softwood to avoid damage to the aluminium extrusion). Any necessary work can now be carried out (when working take care not to knock the supports out of place).

Please contact Glazing Vision for further assistance – the product will no longer be operational. Once the issue is resolved, the product should be reassembled then re-initialised.

Re-Initialisation

If the manual override has been used the product may require re-initialising. Once mains power has been restored, re-initialise the product by pressing close on the control switch. The product is then ready to resume normal service.

If further assistance is required, contact Glazing Vision to arrange for an engineer to visit and resolve the issue.

Chain Actuated Visionvent Troubleshooting

If the vent fails to operate, please check the mains supply is switched on and all connections are terminated correctly.

If further assistance is required, contact Glazing Vision to arrange for an engineer to visit and resolve the issue.

Manual Crank Visionvent Operation

Opening and Closing the Manual Crank Visionvent

The product is opened and closed by turning the hook eye on the end of the telescopic spindle with the supplied crank handle. When viewed from below, a clockwise rotation opens the product. When closing the product take care not to over tighten the telescopic spindle when it reaches the end of its travel to avoid causing damage to the spindle or its fixings. See the installation manual for detailed instructions on how to set up the crank handle to prevent overtravel and possible damage in the closed position.



Figure 11 – Opening/closing spindle

Manual Crank Visionvent Manual Override

If the Manual Crank Visionvent is stuck in the open/closed position and there is an issue with the spindle, then the spindle can be detached from the mounting brackets. If the product is open, then before disconnecting the spindle, prop the lid open on either side using two lengths of timber (it is important to use softwood to avoid damage to the aluminium extrusion). This will prevent the lid from falling when the crank is disengaged. When working take care not to knock the supports out of place. If required, the mounting brackets for the spindle can also be detached from the product. For more information on how to do this, and how to detach the spindle, please see the installation manual.

With the lid no longer supported by the spindle, the weight of the lid can be supported manually allowing the timber supports to be removed. The lid can then be lowered closed slowly (take care – it will be heavy), ensuring not to damage anything. **Do not attempt to lift the lid without a safe working platform.** Do not open the lid past 90°, otherwise the lid will disengage from its extruded hinge and become detached from the base frame. Should this happen, the lid can be reattached by positioning it at approximately 95° to the base and slotting the two halves of the hinge together. When closed, the unit should now be watertight, but not secure.

If further assistance is required, contact Glazing Vision to arrange for an engineer to visit and resolve the issue.

Glass Specification and Breakage Instructions

Glass Specification

Various options are available at time of order. If specific data is required for the glazing, please contact your supplier for a glass data sheet covering the specification installed within your unit.

Breakage Instructions

Glass breakage is not covered under the product warranty. In the event of the glass being damaged please contact Glazing Vision for assistance.

Routine Testing and Maintenance

General Maintenance and Safety

To keep the Visionvent in good working order there are a few basic points that should be observed:

- Do not place anything on, or cause obstruction to the moving section of the product when opening the unit as this may cause damage to the unit's mechanisms and/or prevent it from opening.
- Do not walk or sit on the unit.
- Make sure that fingers and other obstructions are clear of the product and its mechanisms during any operation, severe damage/injury may be caused.
- Do not touch the motors/mechanisms after operating the unit as they may become hot.
- Do not remove the cover plate protecting the control board, as this may allow the controls to become damaged.
- Do not allow unauthorised persons (e.g. children) to operate the product as this may lead to injury or damage to the product.

Specific Maintenance Requirements

Maintenance must only be carried out by suitably qualified personnel*. The following maintenance requirements must be completed and logged on the sheets at the back of this manual. Glazing Vision can offer a service/maintenance contract – please contact us for further details.

*Suitably qualified assumes Glazing Vision Engineers or Approved Installers (installers that have attended a Glazing Vision installation training course for this product and carry 'Approved Installer' status), or an experienced electro-mechanical service engineer.

Monthly Requirements

- The product should be fully opened and closed to ensure that the seals are free, and the mechanisms function evenly.
- Lubricate (WD-40 Specialist High Performance Silicone Lubricant or equivalent) the spindle thread (manual crank only).

Annual Requirements (at least annual - recommended every 6 months)

- Check the integrity of the glazing unit (there should not be any misting or condensation).
- Check that all moving parts are free from debris.
- Grease (Shell Gadus s2 v220 2 or equivalent) the mechanism leadscrews (electric only).
- Lubricate (WD-40 Specialist High Performance Silicone Lubricant or equivalent) all other moving parts and check they move freely.
- Check that the mechanisms are straight and true.
- Check that all fixings are appropriately tightened.
- Check that access to the overrides is clear and advise the relevant party to amend if not.
- Check all electrical cables and ensure that they are not trapped and/or damaged (electric only).
- Check that no water is in the unit.
- Clean and inspect all rubber/silicone seals, contact Glazing Vision to arrange for replacement seals to be fitted if required.
- Check that electrical connections are well made and secure (electric only).
- Check that the control switch does not show any errors (electric only).
- Test the operation.
- Test any optional extras present (electric only).

Every 5 Years

- Replace backup batteries (if present).

Cleaning Requirements

Regular cleaning should be carried out, increasing the frequency if the area is subject to excess debris such as falling leaves or heavy soiling from atmospheric pollution. Due to the Visionvent's unique bonding method and the pitch built into the upstand, there should be no water ponding on the glass when installed correctly.

Any standard glass cleaning product can be used to clean the glass units. However, take care not to use abrasive materials or cleaners as this may affect the unit and its finish. The framework of the unit can be cleaned using warm soapy water with a soft lint free cloth. It is important to avoid getting water into the internal channels of the product framework. Therefore, Glazing Vision highly recommends carrying out any cleaning of the product whilst in the closed position.

- Clear any debris from and around the unit.
- Clean the glass and inspect the integrity of the glazing unit.
- Clean the frame and inspect the finish integrity.
- Clean and inspect all rubber/silicone seals, contact Glazing Vision to arrange for replacement seals to be fitted if required.
- Clean the rain sensor (if present).

Disposal at End of Life

Glazing Vision design products with ease of recyclability at end of life in mind. Many of the main components used are widely recyclable and we encourage you to recycle the unit and/or dispose of the component parts responsibly, in accordance with the guidance from your local authority.

This product comprises the following materials:

Aluminium framework and corner brackets	Widely accepted for recycling at local recycling depots.
Stainless steel (Fixings, nuts, bolts, screws, brackets etc.)	Widely accepted for recycling at local recycling depots.
Glass	Widely accepted for recycling. Check disposal locations with your local recycling depot.
PVC/nylon/plastic	Recyclable - check disposal with your local recycling depot.
Rubber seals and silicone sealant	Not currently recyclable.
Electrical components	If your unit is repaired or decommissioned by Glazing Vision, we will remove and recycle the electrical components under our producer obligations. Alternatively, please dispose of as Waste Electrical and Electronic Equipment (WEEE) at your local recycling depot.
Batteries	If your unit is repaired or decommissioned by Glazing Vision, we will remove and recycle any batteries under our producer obligations. Alternatively, please dispose of as segregated battery waste at your local recycling depot.

Security and Certification

The Visionvent is designed with security as a priority. The mechanisms cannot be back driven and cannot be tampered with from the outside. It is tested to LPS2081 Issue 1:2015. It is approved by the Loss Prevention Certification Board (Cert/LPCB ref: 1347a) and Secured by Design:

Secure (Security Rating A)

The inner pane must be at least 8.8 mm PVB laminated glass (two 4 mm thick panes separated by an 0.8 mm thick PVB interlayer).

Secure+ (Security Rating B) (Electric Visionvent only)

The inner pane must be at least 9.5 mm ionomer laminated glass (two 4 mm thick panes separated by a 1.5 mm thick ionomer interlayer).

Serial Number

Each Glazing Vision product has a unique serial number. A label giving this serial number is affixed to the exterior of Visionvent. This number should be recorded within the maintenance log section of this manual for future reference. If you need to contact us for any reason, Glazing Vision may ask for the product's serial number to enable us to assist with your enquiry.



Warranty Information

A warranty document will be provided with the product. If this is misplaced it can be found at www.glazingvision.com. To ensure the warranty is maintained, the product must be regularly maintained/serviced in accordance with the instructions in this manual.

Maintenance Log

Project Address:

Unit Serial Number:

Work Completed	Notes	Name	Date
Annual Requirements yes/no Battery Replacement yes/no Cleaning Requirements yes/no			
Annual Requirements yes/no Battery Replacement yes/no Cleaning Requirements yes/no			
Annual Requirements yes/no Battery Replacement yes/no Cleaning Requirements yes/no			
Annual Requirements yes/no Battery Replacement yes/no Cleaning Requirements yes/no			
Annual Requirements yes/no Battery Replacement yes/no Cleaning Requirements yes/no			
Annual Requirements yes/no Battery Replacement yes/no Cleaning Requirements yes/no			
Annual Requirements yes/no Battery Replacement yes/no Cleaning Requirements yes/no			
Annual Requirements yes/no Battery Replacement yes/no Cleaning Requirements yes/no			
Annual Requirements yes/no Battery Replacement yes/no Cleaning Requirements yes/no			
Annual Requirements yes/no Battery Replacement yes/no Cleaning Requirements yes/no			
Annual Requirements yes/no Battery Replacement yes/no Cleaning Requirements yes/no			
Annual Requirements yes/no Battery Replacement yes/no Cleaning Requirements yes/no			
Annual Requirements yes/no Battery Replacement yes/no Cleaning Requirements yes/no			
Annual Requirements yes/no Battery Replacement yes/no Cleaning Requirements yes/no			
Annual Requirements yes/no Battery Replacement yes/no Cleaning Requirements yes/no			
Annual Requirements yes/no Battery Replacement yes/no Cleaning Requirements yes/no			
Annual Requirements yes/no Battery Replacement yes/no Cleaning Requirements yes/no			
Annual Requirements yes/no Battery Replacement yes/no Cleaning Requirements yes/no			

Work Completed	Notes	Name	Date
Annual Requirements yes/no Battery Replacement yes/no Cleaning Requirements yes/no			
Annual Requirements yes/no Battery Replacement yes/no Cleaning Requirements yes/no			
Annual Requirements yes/no Battery Replacement yes/no Cleaning Requirements yes/no			
Annual Requirements yes/no Battery Replacement yes/no Cleaning Requirements yes/no			
Annual Requirements yes/no Battery Replacement yes/no Cleaning Requirements yes/no			
Annual Requirements yes/no Battery Replacement yes/no Cleaning Requirements yes/no			
Annual Requirements yes/no Battery Replacement yes/no Cleaning Requirements yes/no			
Annual Requirements yes/no Battery Replacement yes/no Cleaning Requirements yes/no			
Annual Requirements yes/no Battery Replacement yes/no Cleaning Requirements yes/no			
Annual Requirements yes/no Battery Replacement yes/no Cleaning Requirements yes/no			
Annual Requirements yes/no Battery Replacement yes/no Cleaning Requirements yes/no			
Annual Requirements yes/no Battery Replacement yes/no Cleaning Requirements yes/no			
Annual Requirements yes/no Battery Replacement yes/no Cleaning Requirements yes/no			
Annual Requirements yes/no Battery Replacement yes/no Cleaning Requirements yes/no			
Annual Requirements yes/no Battery Replacement yes/no Cleaning Requirements yes/no			
Annual Requirements yes/no Battery Replacement yes/no Cleaning Requirements yes/no			
Annual Requirements yes/no Battery Replacement yes/no Cleaning Requirements yes/no			
Annual Requirements yes/no Battery Replacement yes/no Cleaning Requirements yes/no			
Annual Requirements yes/no Battery Replacement yes/no Cleaning Requirements yes/no			