



Installation Manual

Flushglaze

Contents

Section Description	Page
Introduction	3
Safety Information	4
Pre-Installation Preparation	6
Curb Top Trim Installation	9
Installation Procedure – Singlepart Units	10
Installation Procedure – Multipart Units	12
Installation Procedure – Wall Abutted Units	21
Installation Procedure – Glass Fin Units	23
Installation Procedure – Self-Supported/Silicone Joint Units	25
Installation Checks	33
Interior Finishing	33

Introduction

Thank you for purchasing a Glazing Vision Flushglaze. In order to ensure that it gives you many years of service it is important that before commencing any work you read these instructions fully and ensure that they are strictly followed for a successful and trouble free installation.

We recommend that the installation should be undertaken by Glazing Vision Engineers or Approved Installers (installers that have attended a Glazing Vision Installation training course for this product and carry 'Approved Installer' status). This will ensure a reliable product and enable the property owner to benefit from the full 10 year warranty on the product. It should be noted that an installation by non-approved installers will result in a reduced warranty period of just 2 years.

By following the correct installation procedure, a reliable and high performing end result is guaranteed. The critical operations that can lead to problems if not done correctly are the lifting, preparation of the curb, and ensuring the correct line and level when mounting. Taking the time to carry out these operations correctly will ensure that the product does not twist or distort making sure that the installed product has no undue stresses in the frame or glass.





Care should be taken when working on the product, avoiding accidental damage and ensuring product reliability.

Should you have any queries beyond this manual please do not hesitate to contact Glazing Vision.



Safety Information

Installation of your skylight may involve working at heights, working at an unusual angle, being in unfamiliar locations or all of these. **Before** work is commenced, stop and consider the best way to carry out the task and what hazards you might encounter.

	<p>Let our experts carry out your routine maintenance with a maintenance contract. Contact: www.glazingvision.com/contact</p>
	<p>These products can be very heavy. Extreme care must be taken during handling and installation. Full consideration should be given to how you will safely transport your skylight product from the delivery vehicle to the installation location. Glazing Vision strongly recommends that specialist, mechanical lifting equipment is employed.</p>
	<p>Consider:</p> <ul style="list-style-type: none"> • The weight(s) of the product purchased. • How you will safely transport your skylight product from the delivery vehicle to the installation location. • All lifting methods and equipment required for safe installation to eliminate manual handling. • How you will safely access the area to carry out installation. • Any openings, voids or unprotected edges that might pose a significant risk whilst working at height. • Use of scaffolding with all appropriate edging, rails and inspection certification. • If specialist access or equipment is required e.g. a fall arrest system. • What personal protective safety equipment (PPE) is required for working at height – e.g. harness. • Methods for safe working, for example, to avoid falling from height, reducing manual handling and so as not to drop equipment. • How you will transport tools and other equipment to the installation area. • The number of persons required to assist with safe installation. • The competence, capability and experience of the installation team to safely carry out the task. • Impact of weather on safe installation, especially driving rain and high winds. <p>If in doubt, please contact Glazing Vision for assistance.</p>
	<p>Anticipated hazards may include:</p> <ul style="list-style-type: none"> • Falls from height • Working with specialist lifting equipment or third-party lifting • Manual handling injury • Equipment falling from height • Slips, trips and falls • Fragile roof areas. • Finger or clothing entrapment under unit, in mechanical or moving parts • Impact of weather conditions • Competence of personnel
	<p>Do not attempt to repair, move or dismantle the product unless suitably competent and qualified to do so, with the appropriate safety measures in place. Any repairs and/or movement of the product may invalidate the warranty. Please seek advice from Glazing Vision.</p>



Warning

The following warnings are here to prevent personal injury and damage to the product. Please follow them explicitly.

General:

- The product must be properly installed and commissioned in accordance with this manual before it is used.
- Glazing Vision strongly recommends that any work is carried out by suitably qualified individuals (e.g. Glazing Vision Engineers or Approved Installers, or an experienced service engineer).
- Glazing Vision strongly recommends that specialist, mechanical lifting equipment is employed.
- Use the product only for its intended purpose.
- Regular cleaning and maintenance must be carried out according to guidelines.
- A safe working platform must be provided for any installation/maintenance work carried out. This includes suitable edge protection.
- Glazing Vision cannot be held responsible for damage incurred during the lifting and transportation of the product to the installation location (please refer to terms and conditions of sale).

Pre-Installation:

- Glazing Vision products are heavy, fragile and of awkward shape and size. There may be uneven weight distribution due to the materials used and their design.
- The weight(s) of each individual product (or product section) will be clearly marked on the product and will be communicated to clients before despatch of goods.
- Never install any product showing signs of damage. If in doubt consult Glazing Vision for advice.
- Please dispose of the packaging material for this product in a considerate manner. Cardboard and wood items are widely recycled.

During Use:

- Do not place anything on, walk or sit on the unit (except if a walk-on unit).

For more information or assistance please contact Glazing Vision.

Pre-Installation Preparation



These products can be very heavy. Due consideration should be given to getting the product onto the roof safely and extreme care taken during installation.

Points to Note Prior to Commencing Installation

1. The Flushglaze should arrive on site in undamaged packaging, which includes a wooden build frame/blocks, cardboard, polyfoam glass protection and low tack tape. Please inspect for damage to packaging and/or product and advise Glazing Vision of any damage or shortfall within 48 hours from signing the receipt of your delivery.
2. Enclosed within the box containing this manual will be the required number of fixing woodscrews and a number of plastic packers, as well as some silicone and other required materials and any additional optional items selected at the time of order.

Standard Installation Hardware

Enclosed within the hardware box for each unit you should find at least the following:

Stainless steel woodscrews



Plastic horseshoe packers

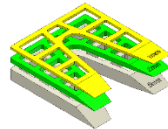

(various sizes)

Low modulus silicone

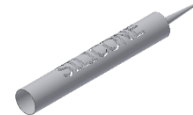

Multipart Units

If a multipart unit is specified, the following items should also be included:

Joining plates



Polyethylene backing rod

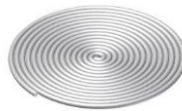

Low modulus silicone



Secondary Seal

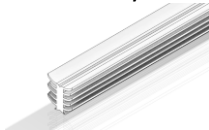

Flashing Tape

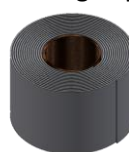

Drainage Hole Covers



Back-to-Back Angle Units

If a multipart unit with back-to-back angles is specified, the following item should also be included:

Countersunk sex bolts



Wall Abutted Units

If a unit with wall abutments is specified, the following item should also be included:
Expanding bolts (or wall plugs)



Glass Fin Units

If a multipart unit with glass fins is specified, the following items should also be included:

Glass fin brackets and fixings



Black EPDM rubber sheet



Black silicone sheet



Fire Rated Units

If a fire rated unit is specified, the following items should also be included (instead of low modulus silicone):

Fire-rated ceramic tape



Fire-rated silicone



- The curb must already be in place for the product. The dimensioning of the product will have taken into consideration the external dimensions of the curb including all weathering. More information about curb construction can be found in Glazing Vision's sales drawings. **Please note that a minimum distance of 6" clearance between the curb and any surrounding structures must be left on all sides. Sufficient room for installation and maintenance must also be allowed for.**
- It is important to ensure that the area of installation is suitably prepared. The area surrounding the curb should be clear to provide safe access during the installation works. It will be necessary to work on the inside and outside and therefore suitable provisions should be made for safe handling of the product, including all relevant personal protective equipment (PPE) and safety systems for working at heights.
- Before starting installation, Glazing Vision advises that the physical curb dimensions are cross-checked with those given for the order, to ensure the product will fit. The curb will need to be within $\pm 3/8"$ of the ordered size. The top surface of the curb should be in plane with the skylight (see figure 1) without undulations greater than $\pm 1/16"$. Also check the diagonals to ensure that the curb has been constructed square. The curb must be weathered as per the sales drawings. **If using any metallic waterproofing material, this cannot be applied across the top surface of the curb as this will cause a thermal bridge which can lead to internal condensation and invalidate the product warranty.**

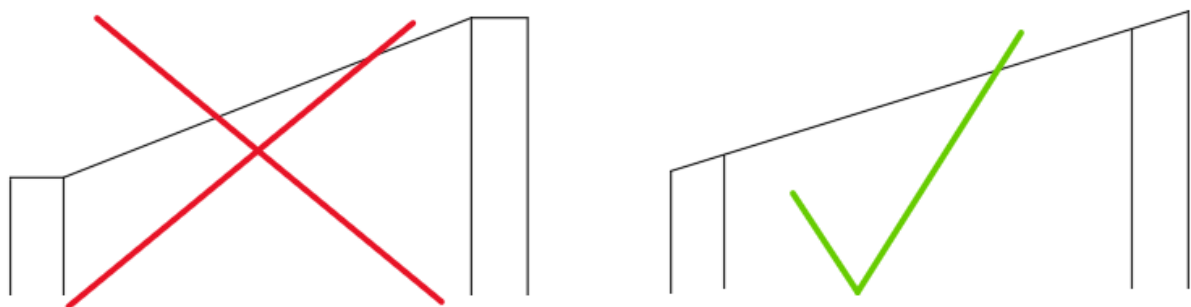

Figure 1 – Curb top surface set-up

6. These products can be very heavy. Glazing Vision strongly recommends that a structural engineer is consulted when designing the structure(s) that will support the product and the surrounding structure. **Nothing in this manual or on Glazing Vision's sales drawings constitutes a structural proposal.**
7. Glazing Vision strongly recommends that a 'dry run' (without any silicone) is completed before committing to the final installation.

Sales Drawings

Sales drawings for the Flushglaze can be obtained by downloading them from Glazing Vision's website or by contacting Glazing Vision.

Curb Top Trim Installation (If Specified)



If you are installing glass fins, the upstand top trim will require trimming around the glass fin brackets, therefore the upstand top trim should be fitted **after** the dry run, and after the glass fin brackets, but before the glass fins are installed. For Singlepart units and units with back-to-back angles, the upstand top trim should be fitted first.

Begin by cutting the curb top trim to the lengths required for all sides of the curb. The corner joints can either be mitred (45°) or straight cut with notches (see image below). If the material requires bending to suit the pitch of the curb, this can be achieved by screwing the section to the curb as below and gently tapping the horizontal part using a clean rubber mallet.

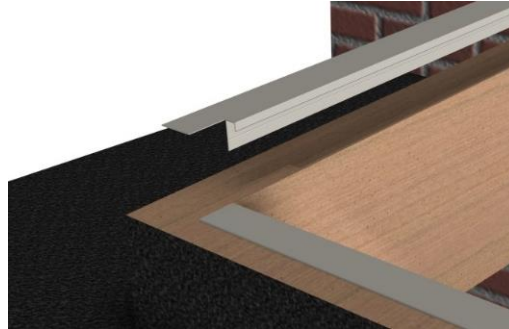

Figure 2 – Curb top trim placement

The curb top trim should be cut to size along its length to leave a dimension of 2-3/8" between the edge of the trim and outside of the curb. This dimension ensures that the visible internal curb top is covered and that there is no contact between the curb top trim and the exterior product framework. The curb top trim is supplied with 5 grooves along the underside. These grooves can be used to help guide a saw or similar when trimming the cover to size. **Failure to follow this step exactly may result in a thermal bridge.**

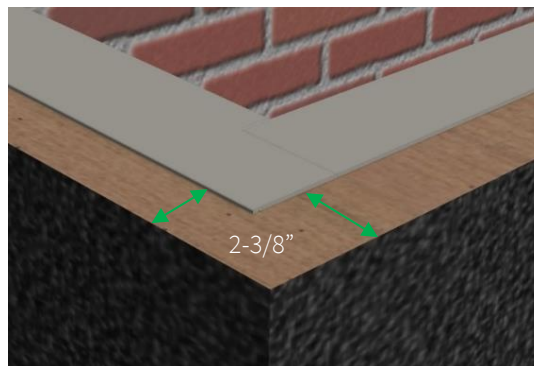

Figure 3 – Curb top trim measurements

After all curb top trim lengths have been cut to size and adjusted to fit, they can be fixed into place with the supplied fixings. Drill holes at approximately 19-3/4" centres using the groove to aid with positioning of the drill bit. The curb top trim has been designed to accept standard 1/2" plasterboard to ensure a flush finish. Refer to the sales drawings for more information.

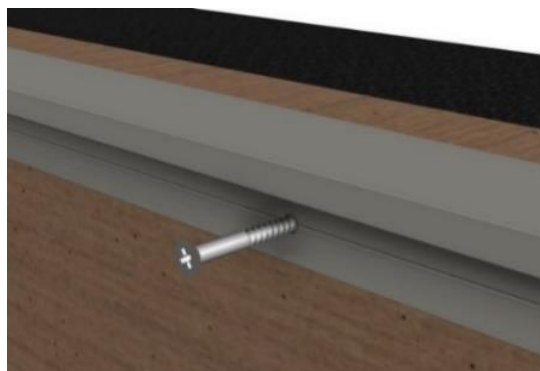

Figure 4 – Curb top trim fixings

Installation Procedure - Singlepart Units



If the unit has wall abutments, please refer to the relevant section about wall abutments in this manual before starting installation.



Prior to commencing installation, **photographs of the fully weathered upstand and surrounding area** must be taken and retained for future reference.

Step 1

Remove all packaging from the product including polyfoam glass protection and low tack tape.



When removing the packaging, try to keep it intact as much as possible, so that after installation it can be re-used to protect the product until project completion and final handover.

Gently prise all of the curb fixing clip on covers off the framework drip legs (note that Circular Flushglaze products do not have this feature).

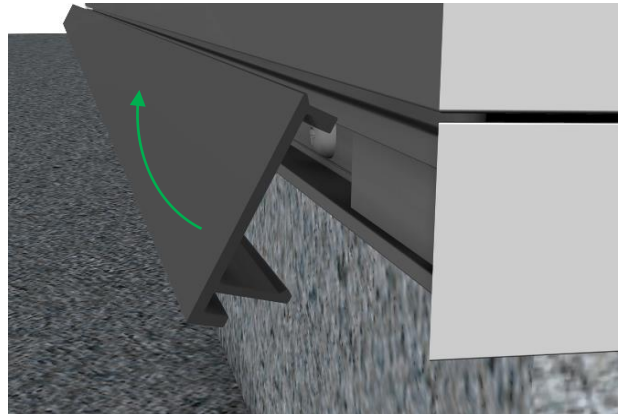

Figure 5 - Clip on cover

Step 2

For Standard and Walk-On Flushglaze units, apply two large lines of silicone (supplied in the installation kit) to the top of the curb. The two lines of silicone need to be approximately 3/4" and 1-5/8" in from the outside face of the curb. For fire rated units, instead of the above, one line of ceramic tape is applied approximately 3/4" from the outer face of the curb, and one line of fire rated silicone is applied 1-5/8" from the outer face of the curb.

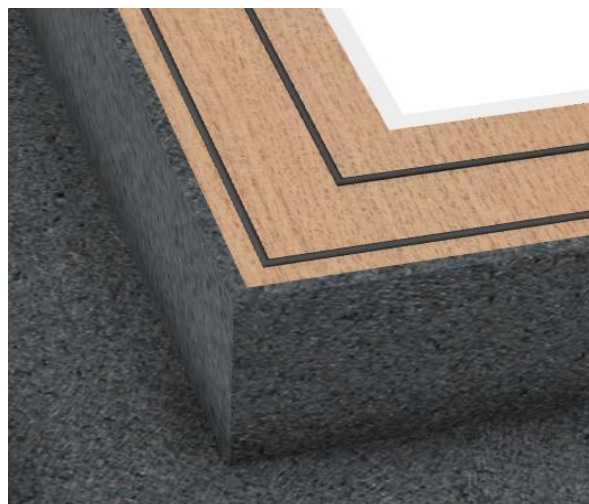

Figure 6 – Silicone placement

Step 3

Fit the chosen lifting equipment to the unit and check that it is secure.

Carefully lift the product to the installation site (roof) using strops underneath the wooden build frame/blocks. This is to ensure that the build frame/blocks do not separate from the product during the lift.

Step 4

When on the roof the product should be lifted off the wooden build frame/blocks (remove the fixings first) and then gently lowered onto the curb.

With the framework in contact with the curb top and the majority of the weight still supported by the crane/lifting equipment, adjust the position of the product on the curb so that the internal framework is equally spaced and aligned with the internal finishes. Take care when positioning the product during final installation, as **once the weight of the unit has been placed onto the sealants it adheres to the curb making repositioning difficult.**

Once satisfied that everything is correctly positioned, carefully release the weight of the product. Remove the crane and lifting equipment.

Step 5

Drill $\text{Ø}1/8''$ pilot holes into the curb through the pre-drilled holes in the product's framework (concealed by the clip on cover). Secure the product to the curb using the woodscrews and packers provided in the hardware kit. The packers must fill the entire gap between the curb and product for each woodscrew. Care should be taken when tightening the fixings to ensure the frame does not distort. Fit the clip on covers back onto the unit (note that Circular Flushglaze products do not have this feature).



If installing into an alternative material to wood, it may be necessary to source suitable wall plugs and/or fixings to use instead of those provided.

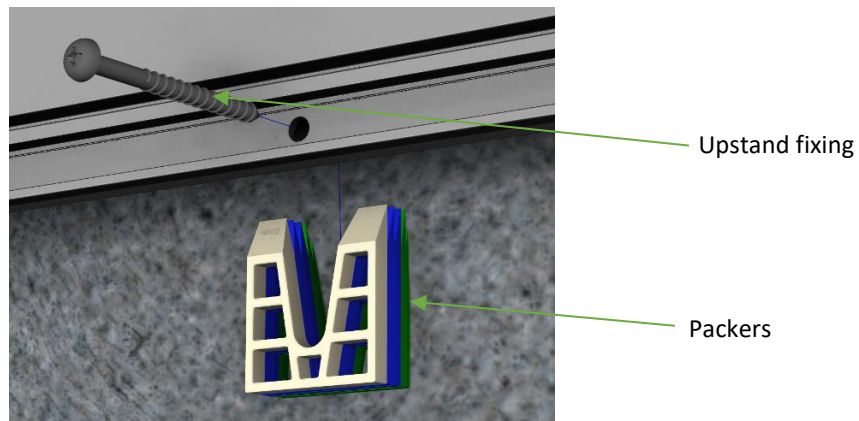

Figure 7 - Curb fixings



Once installation has been completed take **photographs of the finished installation.** These must be retained for future reference.

Installation Procedure - Multipart Units



If you are installing glass fins and/or wall abutments, please refer to the relevant section(s) in this manual before starting installation.



Multipart Flushglazes with glass fins should only be dry fitted with the glass fins in place. This is because the glass fins provide essential support for the glazing units, and without this support the glass may fail.



When all sections of a Multipart Flushglaze are in place during a dry fit, the centre lines should be marked with a pencil onto the upstand/wall. These marks will be used to reposition the unit during final fit. The product can now be installed properly.



Prior to commencing installation, **photographs of the fully weathered upstand and surrounding area** must be taken and retained for future reference.

Step 1



When removing the packaging, try to keep it intact as much as possible, so that after installation it can be re-used to protect the product until project completion and final handover.

Remove all packaging from the product including polyfoam glass protection and low tack tape. Gently prise all of the curb fixing clip on covers off the framework drip legs.

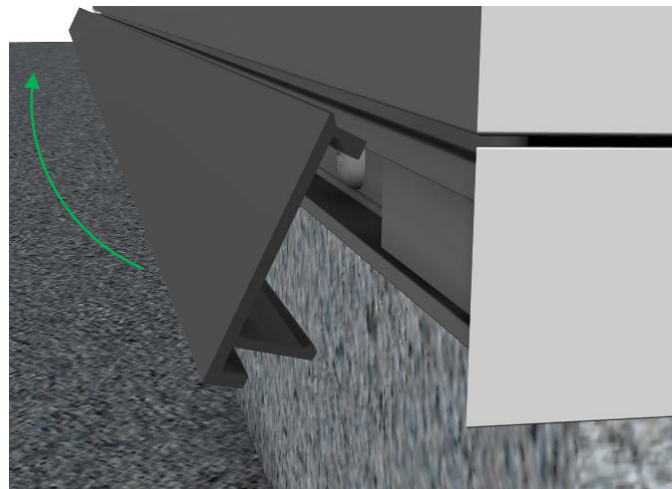

Figure 8 - Clip on cover

Step 2

Exclude Step 2 IF external curb weathering extends on to the top of the kerb.

Apply flashing tape along the curb sticking down 2" on the top face and fold down 1" over the vertical face. This must be applied to the full curb perimeter.

When applying the flashing tape do not overlap the tape, make sure the tape abuts the edges in each corner.

There should be 3/8" gap minimum between the flashing tape and the kerb top trim. **Failure to follow this step exactly may result in a thermal bridge.**

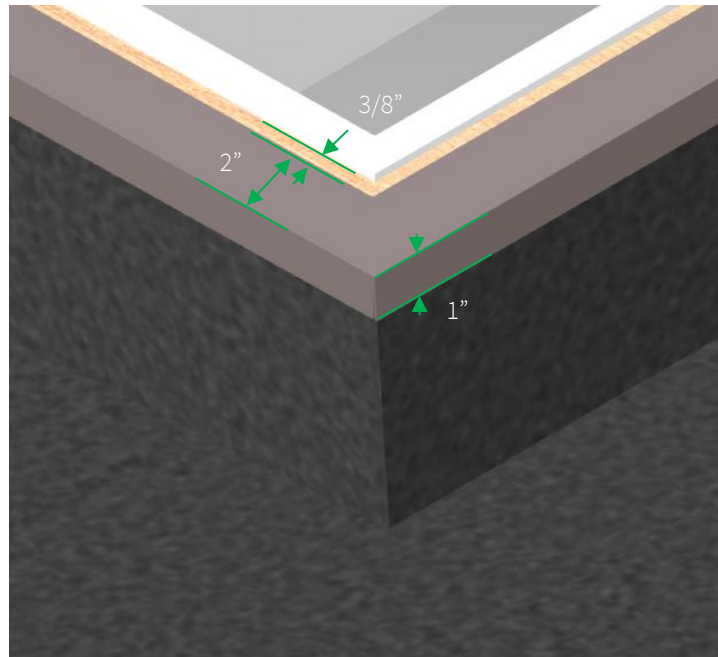

Figure 9 – Flashing Tape

Step 3

Apply two large lines of silicone (supplied in the installation kit) to the curb top surface. The two lines of silicone need to be approximately 3/4" and 1-5/8" in from the outside face of the curb.

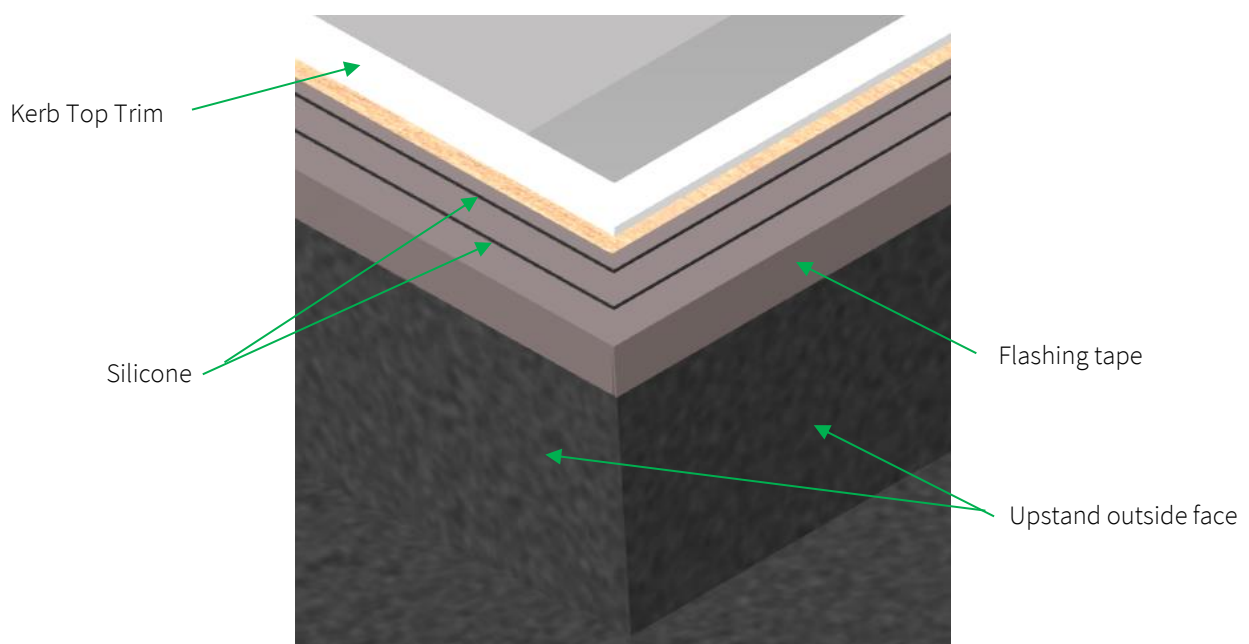

Figure 10 – Flashing tape and Silicone placement

Step 4

Fit the chosen lifting equipment to the unit and check that it is secure.

One section at a time, carefully lift the product to the installation site (roof) using strops underneath the wooden build frame/blocks. This is to ensure that the build frame/blocks do not separate from the product during the lift.

Step 5

The frames have unique identifiers to ensure correct installation. It is important to place the sections with their corresponding letters (on products without back-to-back angles the identifier is located on the underside of the Flushglaze frame). A typical 3 section product would be numbered in the following order:

End of Flushglaze
N40372-RL1-1-A
N40372-RL1-2-A
N40372-RL1-2-B
N40372-RL1-3-B
N40372-RL1-3-C



Figure 11 – Unique identifier number

When on the roof, an end section should be lifted off the wooden build frame/blocks (remove the fixings first) and then gently lowered onto the curb.

With the framework in contact with the curb top and the majority of the weight still supported by the crane/lifting equipment, adjust the position of the section on the curb so that the internal framework is equally spaced and aligned with the internal finishes. Take care when positioning the product during final installation, as **once the weight of the unit has been placed onto the sealants it adheres to the curb making repositioning difficult.**

On units with back-to-back angles, check that the cut outs in the back-to-back angles are suitably sized so that the gap between the structural curb and the back-to-back angle is no more than 3/4". Where the back-to-back angles meet the curb, plastic shims should be placed on top of the curb to fill any voids and ensure that the weight of the sections is carried across the full width of the curb.

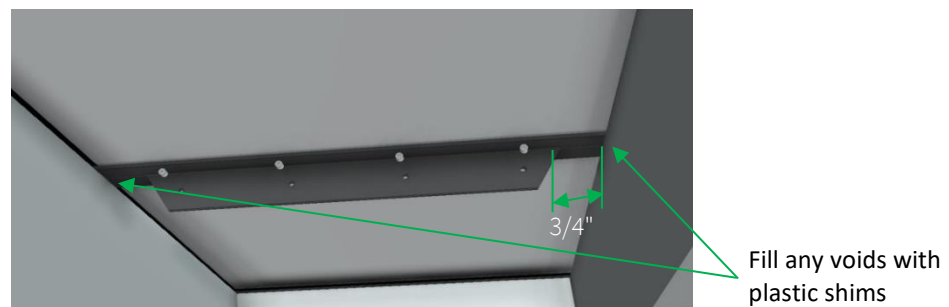

Figure 12 – Back-to-back angles

Once satisfied that everything is correctly positioned, carefully release the weight of the product. Remove the crane and lifting equipment. Repeat for the rest of the sections.



Figure 13 – Section placement

Align each frame section with its adjacent frame using the joining plates supplied. Note that wall abutments do not accommodate a joining plate. Repeat this step for all sections of the product.

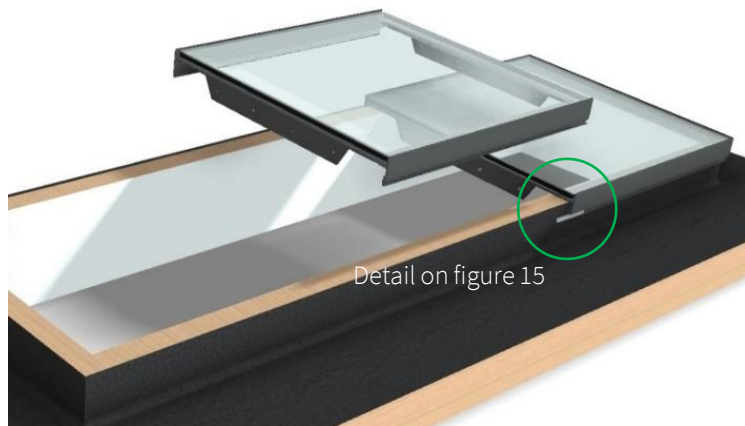

Figure 14 – Joining plate inserted

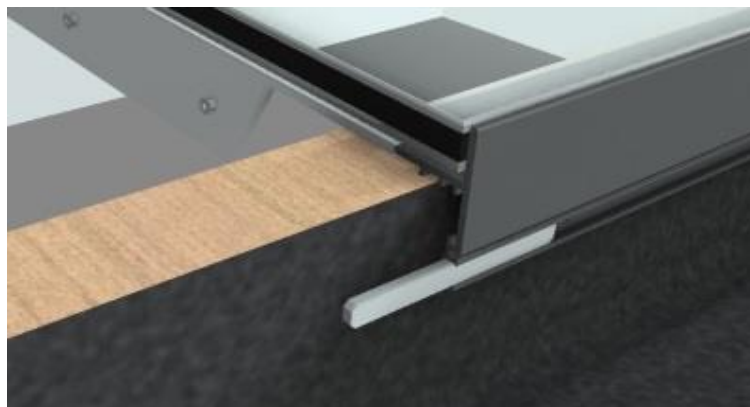

Figure 15 – Joining plate inserted

Step 6

Once installed, the back-to-back angles (if present) can now be fixed together using the countersunk sex bolts (supplied).

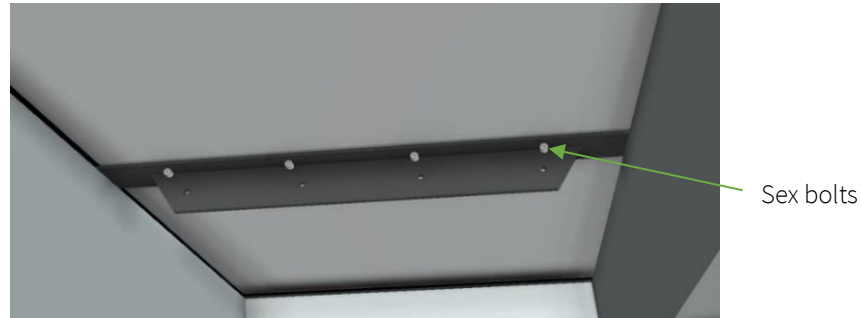

Figure 16 – Back-to-back angle fixing

Step 7

Drill $\varnothing 1/8$ " pilot holes into the curb through the pre-drilled holes in the product's framework (concealed by the clip on cover). Secure the product to the curb using the woodscrews and packers provided in the hardware kit. The packers must fill the entire gap between the curb and product for each woodscrew. Care should be taken when tightening the fixings to ensure the frame does not distort. Fit the clip on covers back onto the unit.



If installing into an alternative material to wood, it may be necessary to source suitable wall plugs and/or fixings to use instead of those provided.

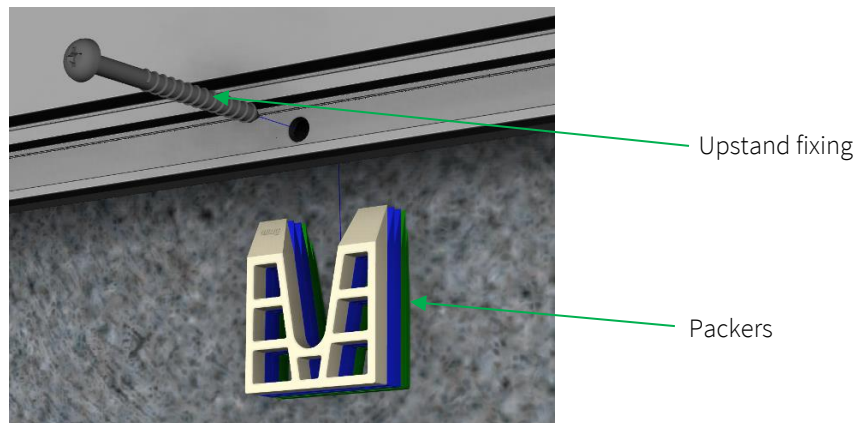

Figure 17 - Curb fixings

Step 8

Once all skylight sections are securely fastened to the curb, the secondary seals should be installed. Start by laying the seal between the glazing joints and cut flush with the frame edges.

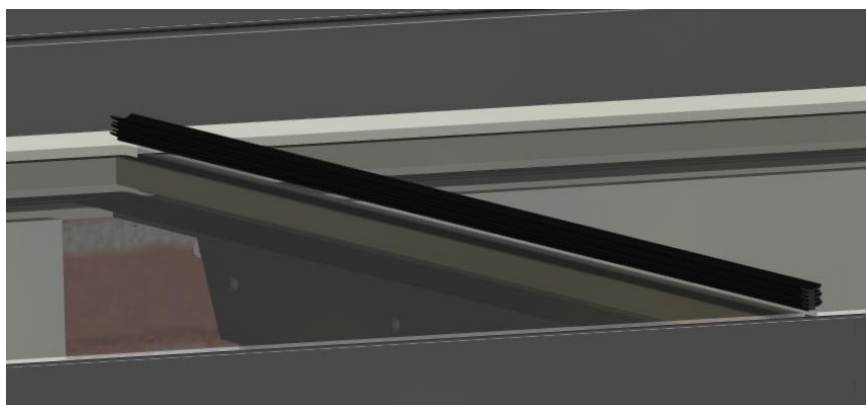

Figure 18 – Secondary Seal Location

Step 9

Begin installing the secondary seal approximately 2” back from the internal surface of the inside of the frame. Work toward the front of the unit and ensure the seal is located as close as possible to the internal surface of the skylight frame. Ensure the seal is not crushed or warped as this will limit the drainage if not corrected.

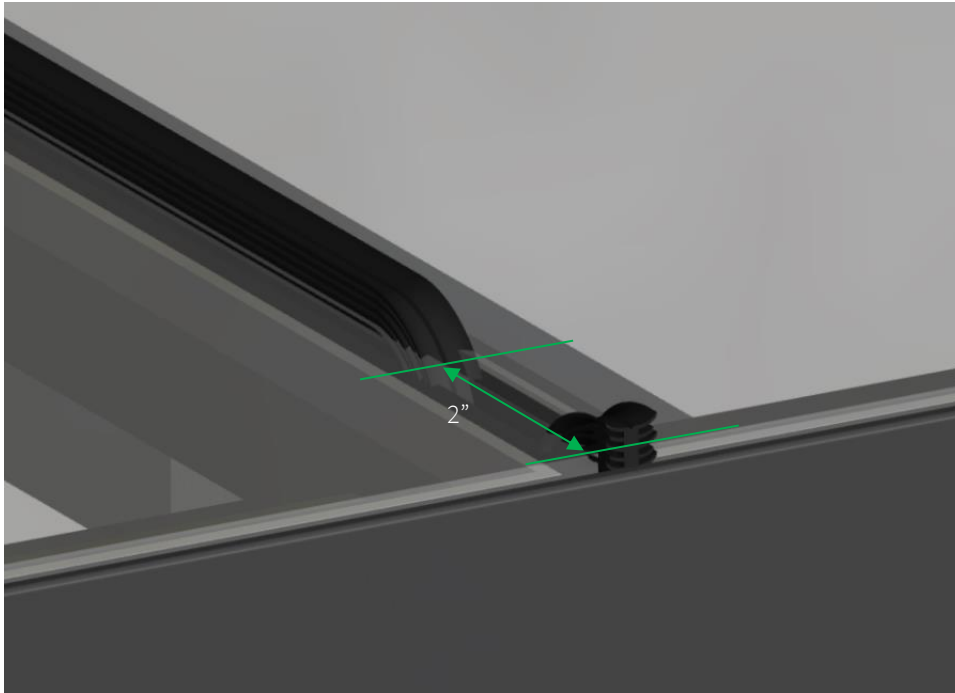

Figure 19 – Installation Starting Location

Step 10

Apply a light tension to the secondary seal, this will make it easier to install along the joint. Use an installation tool, ensure the secondary seal is fitted the full length of the joint(s) to the bottom.

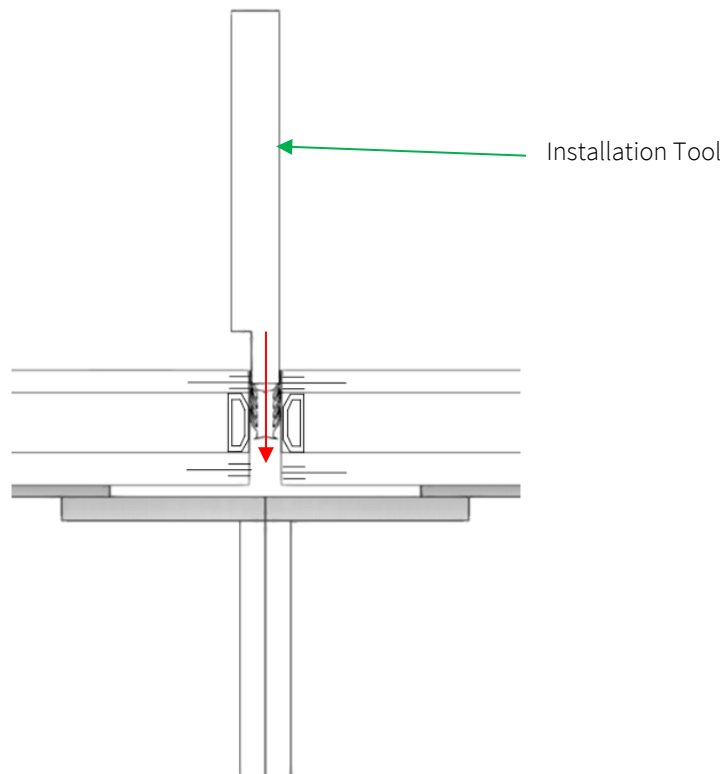

Figure 20 – Secondary Seal Installation

Step 11

Use a sharp blade to trim the secondary seal at the rear of the skylight, aligning the cut with the internal surface of the rear of the skylight frame (as shown in figure 21). Use the installation tool to press in the remaining length of the secondary seal into the groove. Ensure that the end of the seal is fitted well and is not warped or folded after installation.

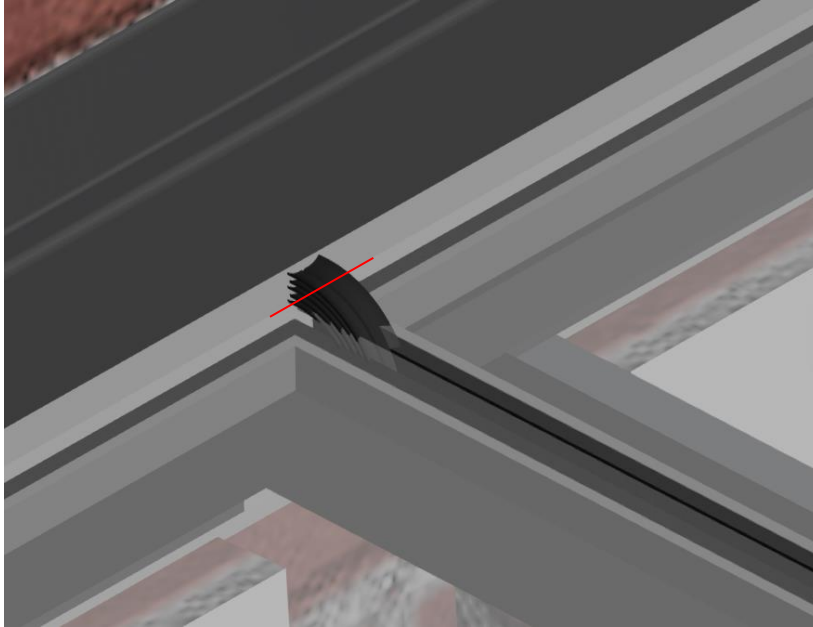

Figure 21 – Rear Seal Trimming Detail

Step 12

Exclude step 12 for walk-on units with a 1" outer pane, see 402-SDD-UK-011 for more detail on this.

Cut the appropriate lengths of polyethylene backing rod to fit over the secondary seal in the same joints between the glass sections. With the secondary seal already in place, insert the backing rod on top of it. Press both the backing rod and the secondary seal together in the gap, ensuring that the backing rod is positioned **5/16"** below the outer surface of the glass. After pressing them into place, wait at least 15 minutes to allow any compressed air to escape from the backing rod (otherwise the air can cause bubbles in wet silicone).

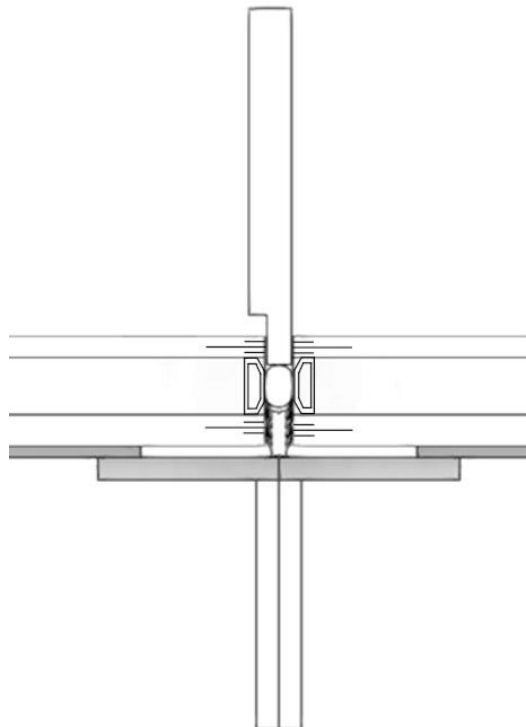

Figure 22 – Backing Rod and Secondary Seal Installation

Step 13



The drainage holes can potentially be blocked when applying the silicone. Care should be taken near the drainage holes to not force silicone into these spaces.

For each joint, apply enough silicone to overfill the joints and tool off the excess silicone (a suggested method is to use the open end of a used silicone tube with some soapy water) to finish the joint. When tooling off the excess silicone, ensure the surface is flush and there are no cavities where water could collect, as this could affect the long-term performance of the seal.

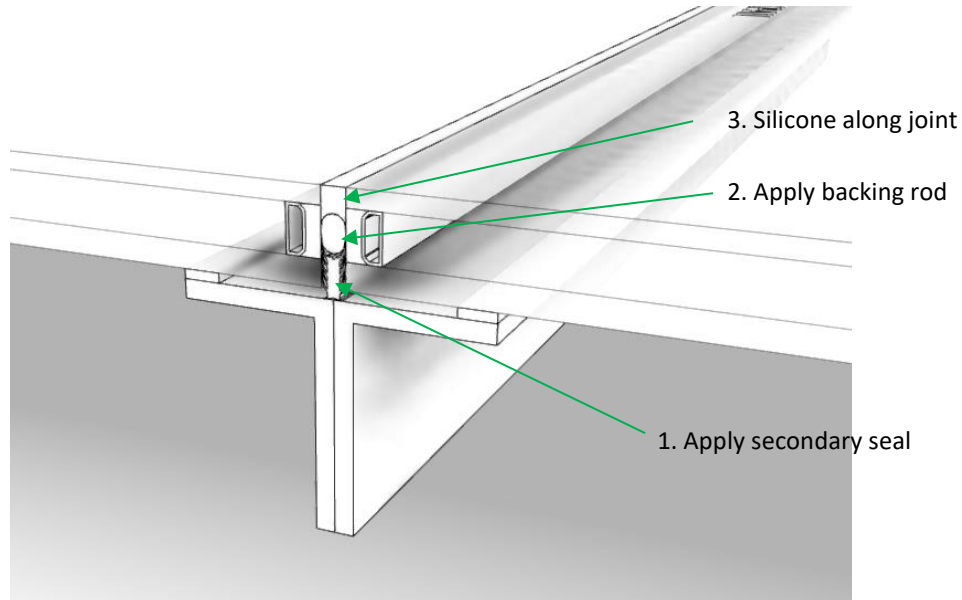

Figure 23 – Back-to-back glazed unit joining

Step 14

Finally, fill the drainage holes at the top of the fall with silicone before fitting the drainage hole covers to prevent water entering the unit. Insert the drainage hole covers into the drainage holes located at opposite ends of the back-to-back.

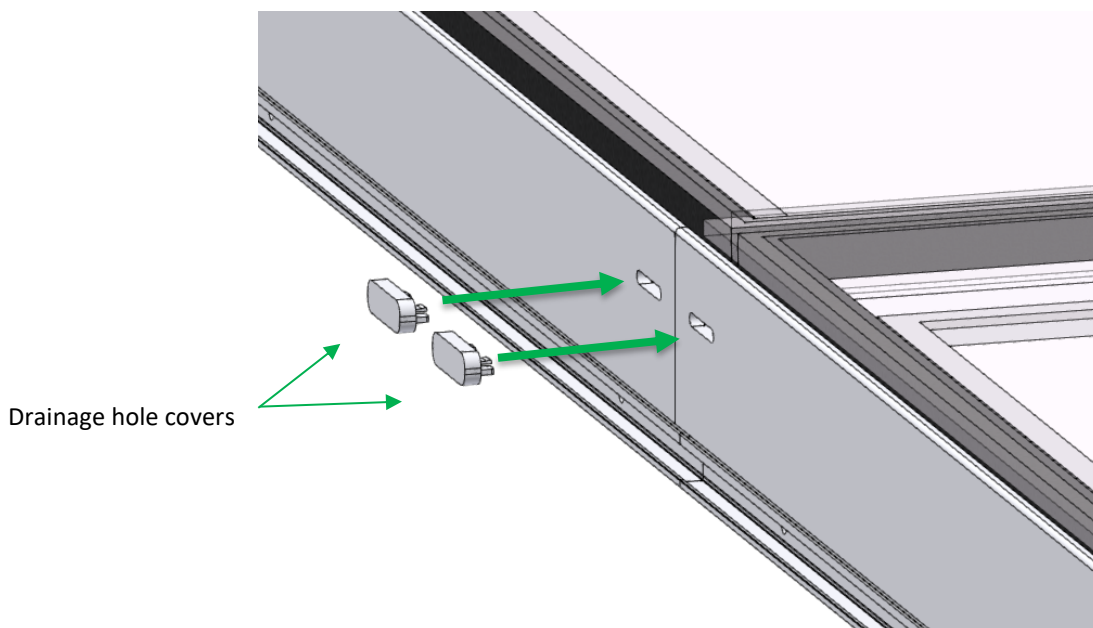

Figure 24 – Drainage hole cover installation

The edges of the frames should sit flush and should not require any finishing. If for whatever reason they do require external finishing, the appropriate colour of silicone to match the framework can be run along the joint.



Once installation has been completed take **photographs of the finished installation**. These must be retained for future reference.

Installation Procedure – Wall Abutted Units



If you are installing glass fins as well as wall abutments, please refer to the relevant section about glass fins in this manual before starting installation.



If the unit is a multipart then refer to the specific multipart installation instructions for detailed section assembly.

A suitable lead (or similar) flashing will be required over the wall abutment following installation. This will need to be done by a builder. To reduce the possibility of damage to the glass it is recommended that any chasing of brickwork for flashings is completed prior to product installation. It is also recommended that temporary battens are secured to the wall to support the weight of the product during installation. The battens should be installed in line with the top of the curb (note the pitch of the product). The battens can be removed when installation is complete.

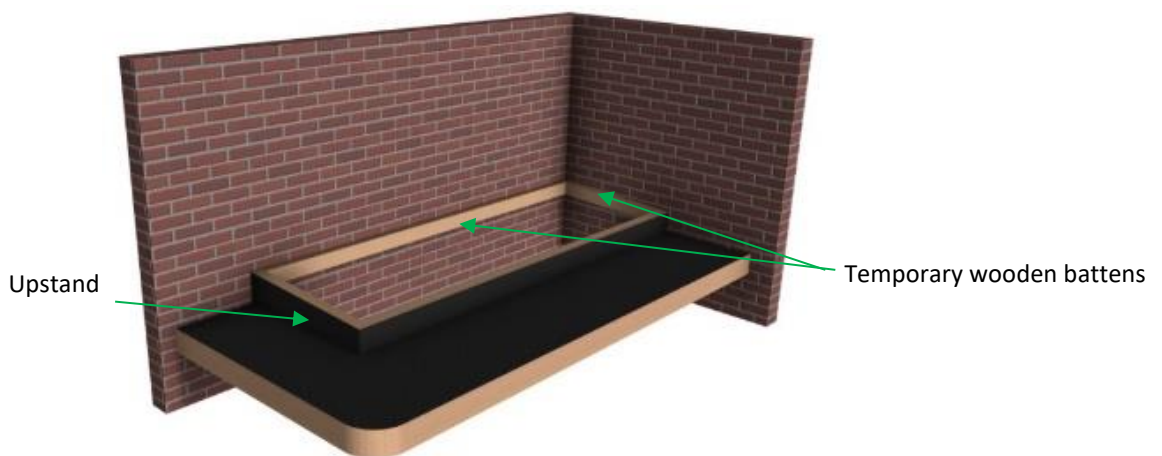

Figure 25 – Temporary wooden support battens in place

Step 1

If not already done so, install the temporary support battens.

Remove all packaging from the product including polyfoam glass protection and low tack tape.



When removing the packaging, try to keep it intact as much as possible, so that after installation it can be re-used to protect the product until project completion and final handover.

Step 2

A dry fit is needed first, so that the fixing holes can be drilled into the wall. Dry fit the product (install without adhesives), then mark the position of the fixing holes through the pre-drilled holes in the product's framework.

Remove the product and drill $\varnothing 1/8''$ holes into the curb. For standard units drill $\varnothing 5/16'' \times 2-3/8''$ holes into the wall. For Walk-On units, drill $\varnothing 3/8'' \times 3-1/8''$ holes into the wall. Insert the wall plugs.

Follow the relevant installation instructions for either a Singlepart or Multipart unit and insert all curb fixings.

Secure the product to the curb using the woodscrews (or expanding bolts for wall abutments on Walk-On Flushglaze units) and packers provided in the hardware kit. The packers must fill the entire gap between the curb and product for

each woodscrew. Care should be taken when tightening the fixings to ensure the frame does not distort. Once the fixings are all in place the temporary support battens can be removed.

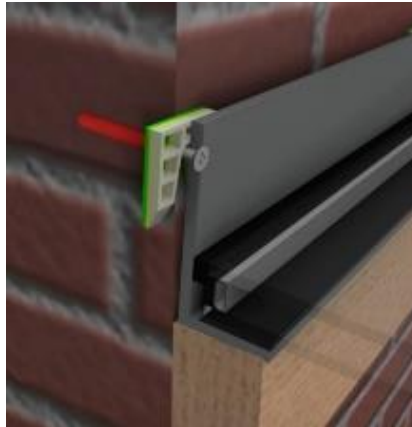

Figure 26 – Wall abutment fixed in place

Step 3

To finish the wall abutments, run a bead of silicone along the edge of the framework, both inside and outside.

Step 4

A suitable lead (or similar) flashing should now be installed over wall abutment. This needs to be done by a builder.

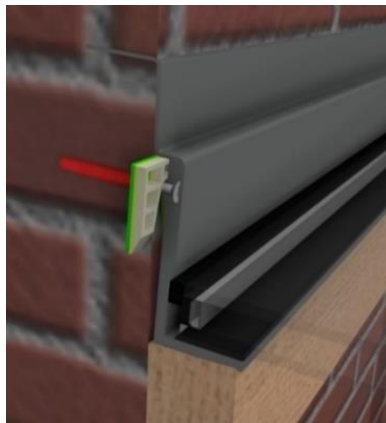

Figure 27 – Lead flashing applied over the wall abutment



Once installation has been completed take **photographs of the finished installation**. These must be retained for future reference.

Installation Procedure – Glass Fin Units



Glass fins are toughened laminated units and should be kept in an upright position to prevent them from sagging as this could cause them to shatter. For glass fins positioned along the pitch there will be one upper (angled) and one lower (angled) bracket per fin. For glass fins positioned across the pitch there will be two right angled brackets.

Step 1

If not already done so, install the temporary support battens for any wall abutments.

Remove all packaging from the product including polyfoam glass protection and low tack tape.



When removing the packaging, try to keep it intact as much as possible, so that after installation it can be re-used to protect the product until project completion and final handover.

Step 2

When installing units with glass fins, marking out is required to ensure accurate location of the support brackets. The location of the brackets is critical to ensure that the glazing is structurally supported. Initially measure the product sections and mark the centrelines between sections.

Measure 2-15/16” to the left of each centreline and mark off on the wall/curb. This represents the location for the left hand edge of the support bracket. The top edge of the back plate of the support bracket should be level with the top surface of the curb.

Step 3

Curb Mounted Glass Fin Brackets

Select the appropriate glass fin support bracket and align the left hand side to the mark made on the curb - so the centre of the bracket is in line with the pencilled centreline and the top of the bracket sits flush with the top of the curb. Drill a pilot hole for each screw fixing and fasten the bracket to the curb using the woodscrews and plastic packers provided ensuring a nominal 3/16” gap from the face of the curb (use wall plugs if needed). Repeat this for all curb mounted glass fin brackets.

Once they are all in place, if curb top trim is being used, it can be trimmed to fit around the glass fin support bracket(s). The front leg (7/16” long) should be trimmed to fit around the protruding bracket, and the back leg (1-7/16” long) should be trimmed to fit around the back plate. Once this is done, the curb top trim can be fitted.

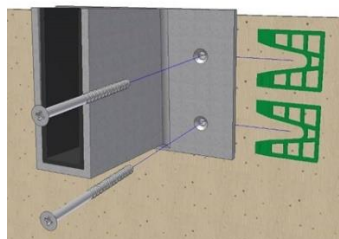

Figure 28 – Fixing a curb mounted glass fin support bracket



Figure 29 – Glass fin support bracket with curb top trim

Wall Mounted Glass Fin Brackets

Select the appropriate glass fin support bracket and align the left hand side to the mark made on the curb - so the centre of the bracket is in line with the pencilled centreline and the top of the bracket sits flush with the top edge of the temporary support batten (installed earlier). Drill a small pilot hole for each screw fixing and fasten the bracket to the curb using the woodscrews, wall plugs, and plastic packers provided ensuring a nominal 3/16" gap from the face of the wall. Repeat this for all wall mounted glass fin brackets.

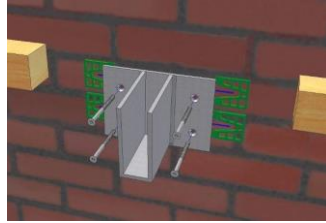

Figure 30 – Fixing a wall mounted glass fin support bracket

Step 4

When all brackets are fixed in place, the glass fins can be placed inside them. Use the supplied 1/8" EPDM rubber to line the fin bracket and protect the glass from any possible contact with the metal. The top of the glass fins will be blacked out on the top side for aesthetic purposes. Ensure if the glass fins have any notches that these are placed upwards (underneath where wall abutments are present) to avoid any contact with product framework. Once installed, check that the glass fins sit approximately 1/4" above the level of the curb, use plastic shims within the glass fin support bracket to raise the level of the glass fin if needed.

To provide support to the glass and as a barrier against glass-to-glass contact, 2-15/16" long strips of silicone sheet should now be placed at intervals across the top of the glass fins leaving 15-3/4" – 19-11/16" gaps between each silicone strip.

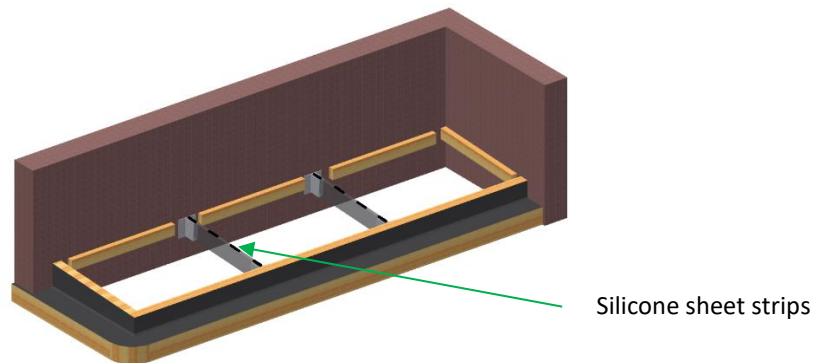

Figure 31 – Silicone sheet strips placed at intervals along the glass fins

The installation can now be continued following the installations for a Multipart unit. Take care not to damage the glass fins.

Once installed, to finish the glass fins, black silicone should be applied along the top of the glass fins, filling the gaps between the silicone sheet strips. Check that no air gaps are present and fill them if needed. To provide an aesthetic finish, a fillet of silicone should then be applied along the edge of the fin between the top of the fin and underside of the glass on both sides of each glass fin.



Once installation has been completed take **photographs of the finished installation**. These must be retained for future reference.

Installation Procedure – Self-Supported/Silicone Joint Units



If you are installing wall abutments, please refer to the relevant section(s) in this manual before starting installation.



When all sections of a Multipart Flushglaze are in place during a dry fit, the centre lines should be marked with a pencil onto the upstand/wall. These marks will be used to reposition the unit during final fit. The product can now be installed properly.



Prior to commencing installation, **photographs of the fully weathered upstand and surrounding area** must be taken and retained for future reference.

Step 1

If not already done so, install the temporary support battens for any wall abutments.

Step 2

Remove all packaging from the product including polyfoam glass protection and low tack tape.



When removing the packaging, try to keep it intact as much as possible, so that after installation it can be re-used to protect the product until project completion and final handover.

Gently prise all of the curb fixing clip on covers off the framework drip legs.

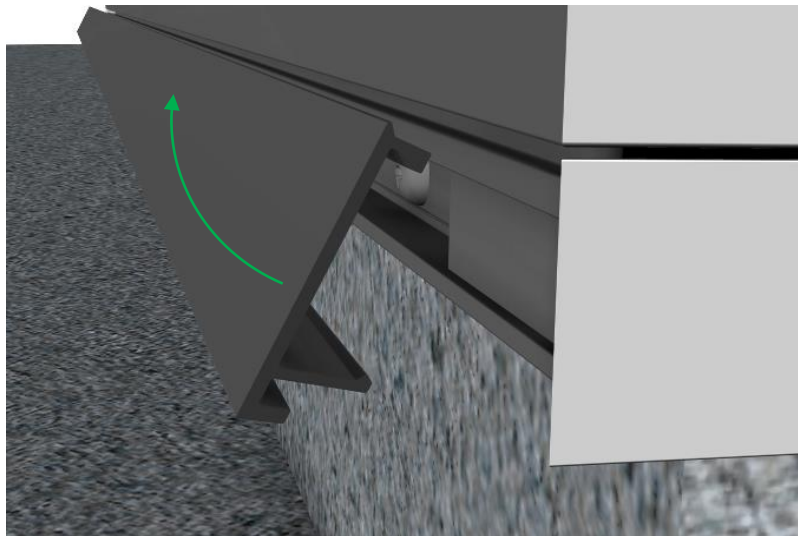

Figure 32 - Clip on cover

Step 2

Exclude Step 2 IF external curb weathering extends on to the top of the kerb.

Apply flashing tape along the curb sticking down 2" on the top face and fold down 1" over the vertical face. This must be applied to the full curb perimeter.

When applying the flashing tape do not overlap the tape, make sure the tape abuts the edges in each corner.

There should be 3/8" gap minimum between the flashing tape and the kerb top trim. **Failure to follow this step exactly may result in a thermal bridge.**

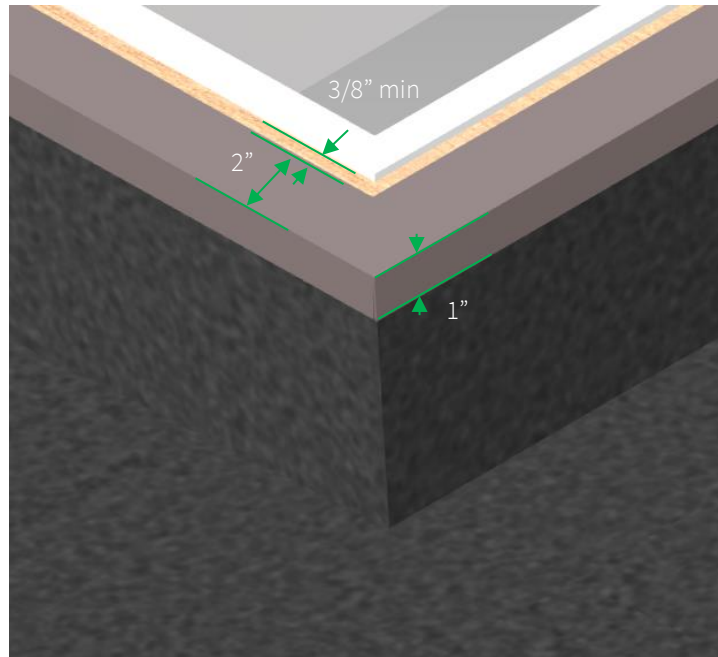

Figure 33 – Flashing Tape

Step 3

Apply two large lines of silicone (supplied in the installation kit) to the curb top surface. The two lines of silicone need to be approximately 3/4" and 1-9/16" in from the outside face of the curb.

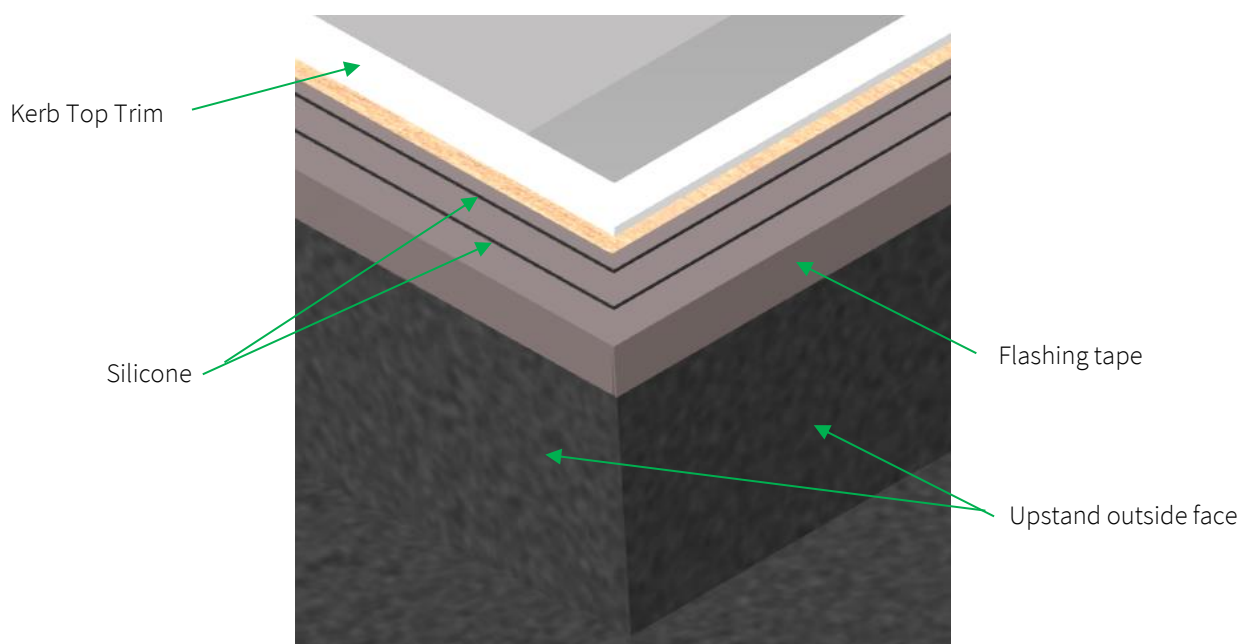

Figure 34 – Flashing tape and Silicone placement

Step 4

Fit the chosen lifting equipment to the unit and check that it is secure.

One section at a time, carefully lift the product to the installation site (roof) using strops underneath the wooden build frame/blocks. This is to ensure that the build frame/blocks do not separate from the product during the lift.

Step 5

The frames have unique identifiers to ensure correct installation. It is important to place the sections with their corresponding letters (on products without back-to-back angles the identifier is located on the underside of the Flushglaze frame). A typical 3 section product would be numbered in the following order:

End of Flushglaze
N40372-RL1-1-A
N40372-RL1-2-A
N40372-RL1-2-B
N40372-RL1-3-B
N40372-RL1-3-C

When on the roof, an end section should be lifted off the wooden build frame/blocks (remove the fixings first) and then gently lowered onto the curb.

With the framework in contact with the curb top and the majority of the weight still supported by the crane/lifting equipment, adjust the position of the section on the curb so that the internal framework is equally spaced and aligned with the internal finishes. Take care when positioning the product during final installation, as **once the weight of the unit has been placed onto the sealants it adheres to the curb making repositioning difficult.**

Once satisfied that everything is correctly positioned, carefully release the weight of the product. Remove the crane and lifting equipment. Repeat for the rest of the sections.



Figure 35 – Section placement

Step 6

Align each frame section with its adjacent frame using the joining plates supplied. Note that wall abutments do not accommodate a joining plate. Repeat this step for all sections of the product.

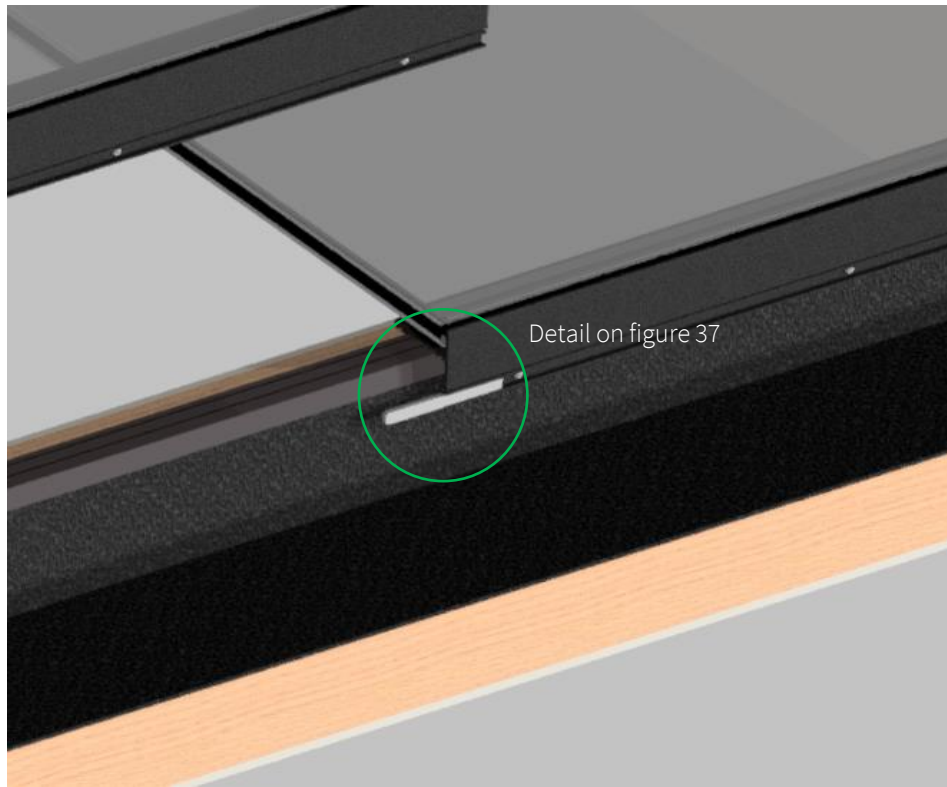

Figure 36 – Joining plate inserted

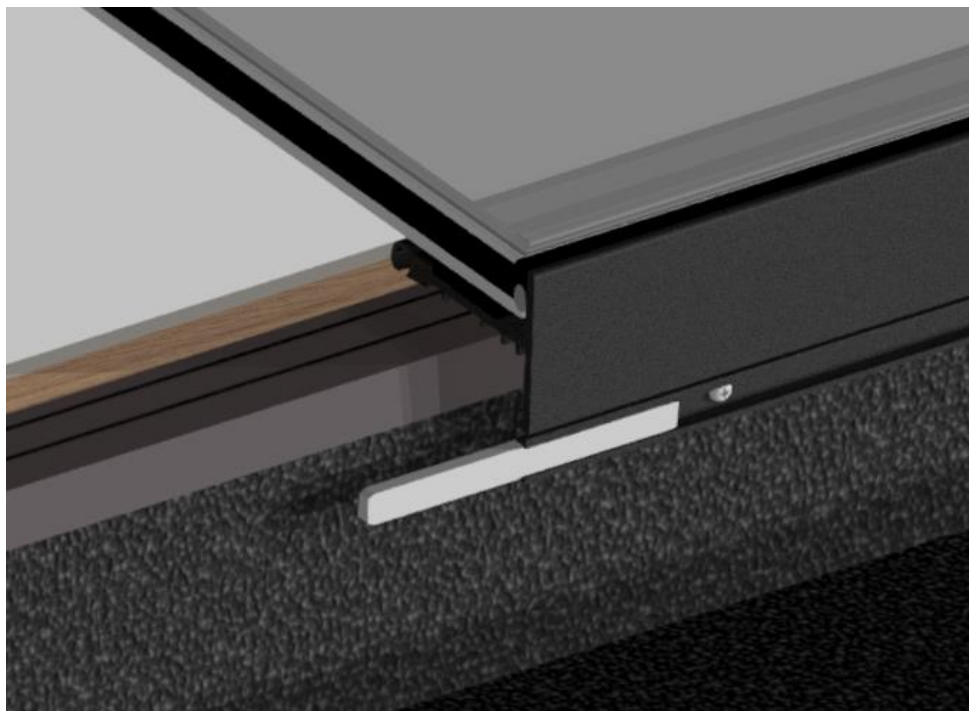

Figure 37 – Joining plate inserted

Step 7



If installing into an alternative material to wood (ie. Concrete), it may be necessary to source suitable wall plugs and/or fixings to use instead of those provided.

Drill $\varnothing 1/8$ " pilot holes into the curb through the pre-drilled holes in the product's framework (concealed by the clip on cover). Secure the product to the curb using the woodscrews and packers provided in the hardware kit. The packers must fill the entire gap between the curb and product for each woodscrew. Care should be taken when tightening the fixings to ensure the frame does not distort. Fit the clip on covers back onto the unit.

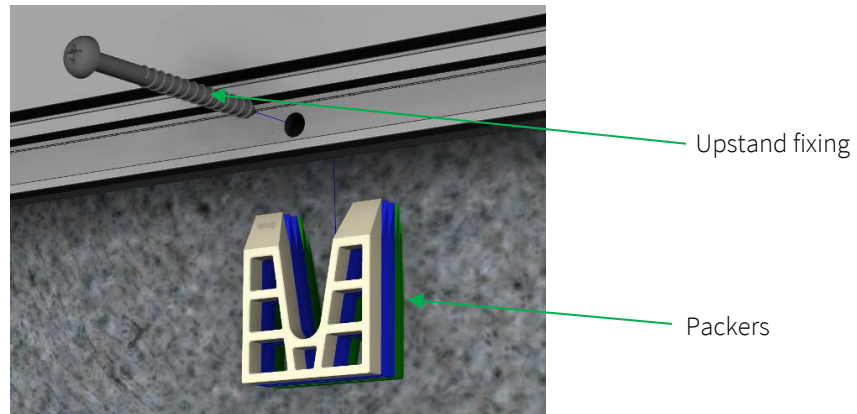

Figure 38 - Curb fixings

Step 8

Once all skylight sections are securely fastened to the curb, the secondary seals should be installed. Start by laying the seal between the glazing joints and cut flush with the frame edges.

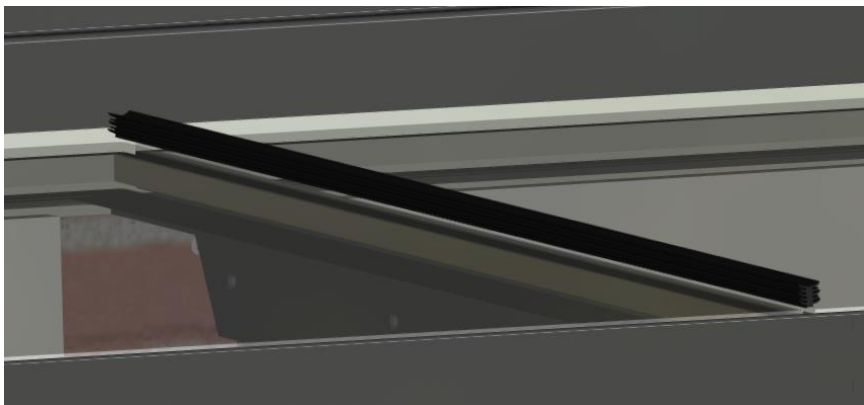

Figure 39 – Secondary Seal Location

Step 9

Begin installing the secondary seal approximately 2" back from the internal surface of the inside of the frame. Work toward the front of the unit and ensure the seal is located as close as possible to the internal surface of the skylight frame. Ensure the seal is not crushed or warped as this will limit the drainage if not corrected.

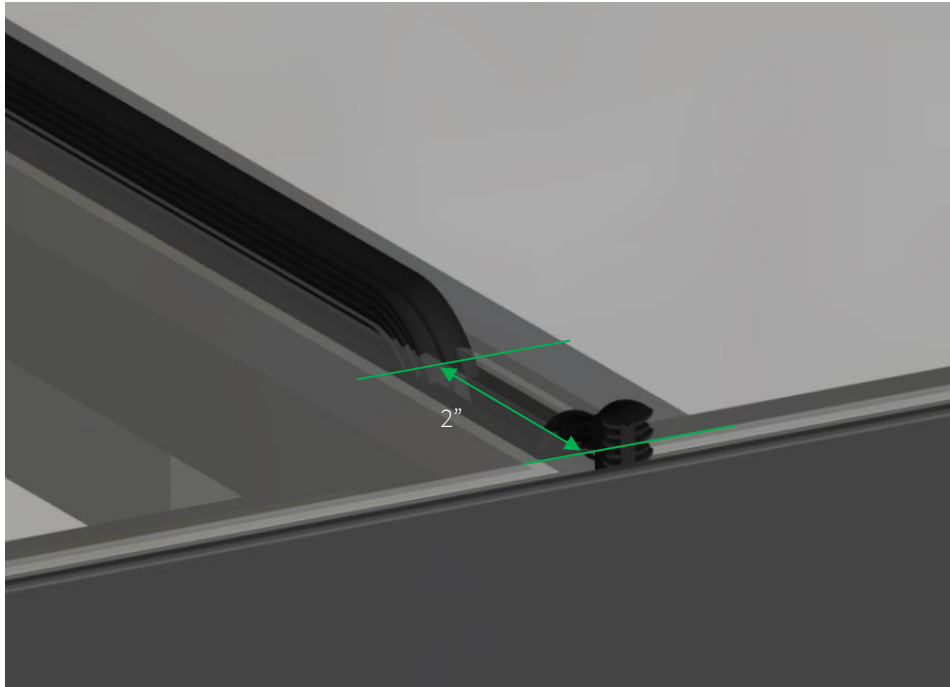

Figure 40 – Installation Starting Location

Step 10

Apply a light tension to the secondary seal, this will make it easier to install along the joint. Use an installation tool, ensure the secondary seal is fitted the full length of the groove(s) to 5/16" from the bottom.

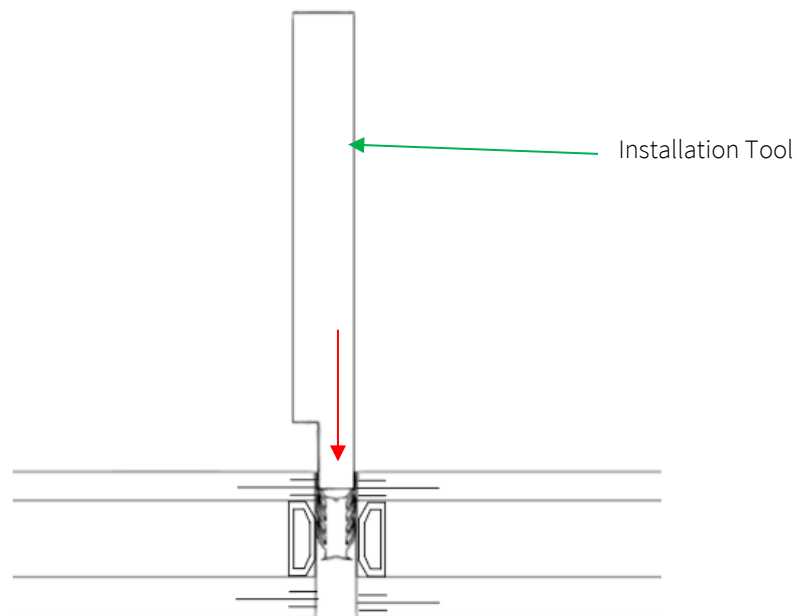

Figure 41 – Secondary Seal Installation

Step 11

Use a sharp blade to trim the secondary seal at the rear of the skylight, aligning the cut with the internal surface of the rear of the skylight frame (as shown in figure 21). Use the installation tool to press in the remaining length of the secondary seal into the joint. Ensure that the end of the seal is fitted well and is not warped or folded after installation.

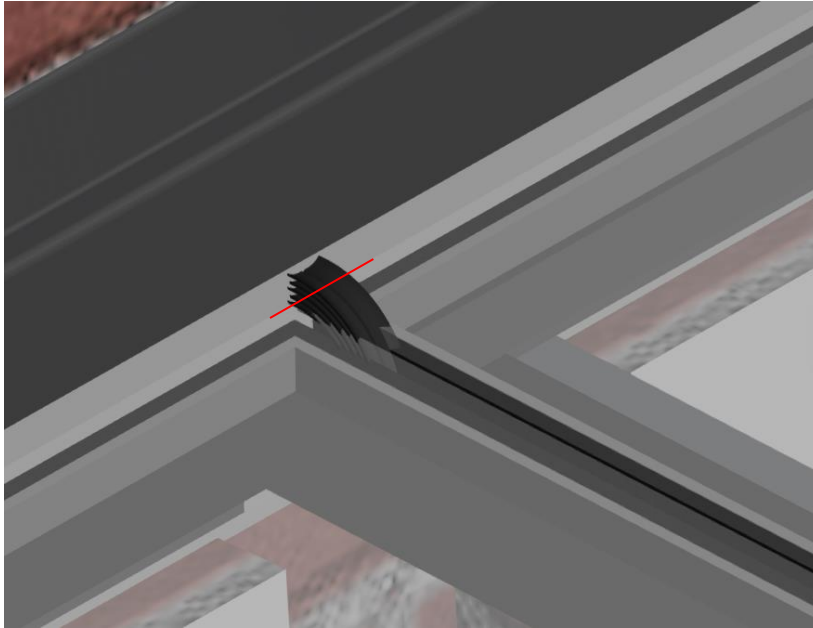

Figure 42 – Rear Seal Trimming Detail

Step 12

Cut the appropriate lengths of polyethylene backing rod to fit over the secondary seal in the same grooves between the glass sections. With the secondary seal already in place, insert the backing rod on top of it. Press both the backing rod and the secondary seal together in the joint, ensuring that the backing rod is positioned **5/16"** below the **outer surface** of the glass. After pressing them into place, wait at least 15 minutes to allow any compressed air to escape from the backing rod (otherwise the air can cause bubbles in wet silicone).

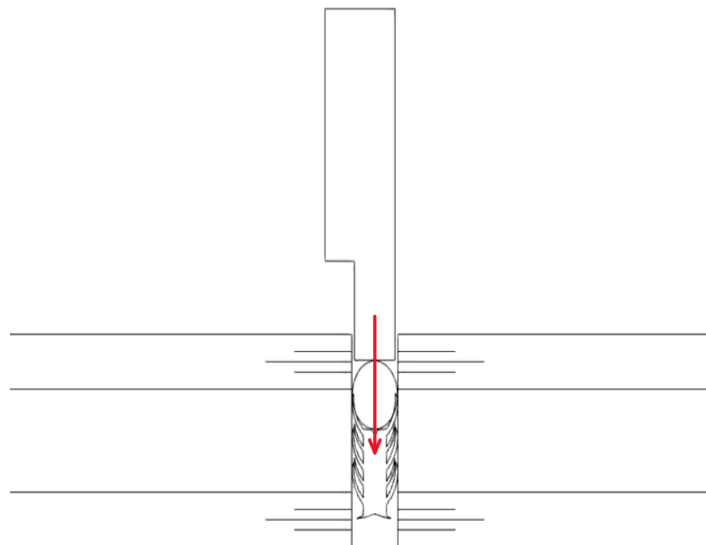

Figure 43 – Backing Rod and Secondary Seal Installation

Step 13



The drainage holes can potentially be blocked when applying the silicone. Care should be taken near the drainage holes to not force silicone into these spaces.

For each gap, apply enough silicone to overfill the joints and tool off the excess silicone (a suggested method is to use the open end of a used silicone tube with some soapy water) to finish the joint. When tooling off the excess silicone, ensure the surface is flush and there are no cavities where water could collect, as this could affect the long-term performance of the seal.

Repeat for each internal edge as well.

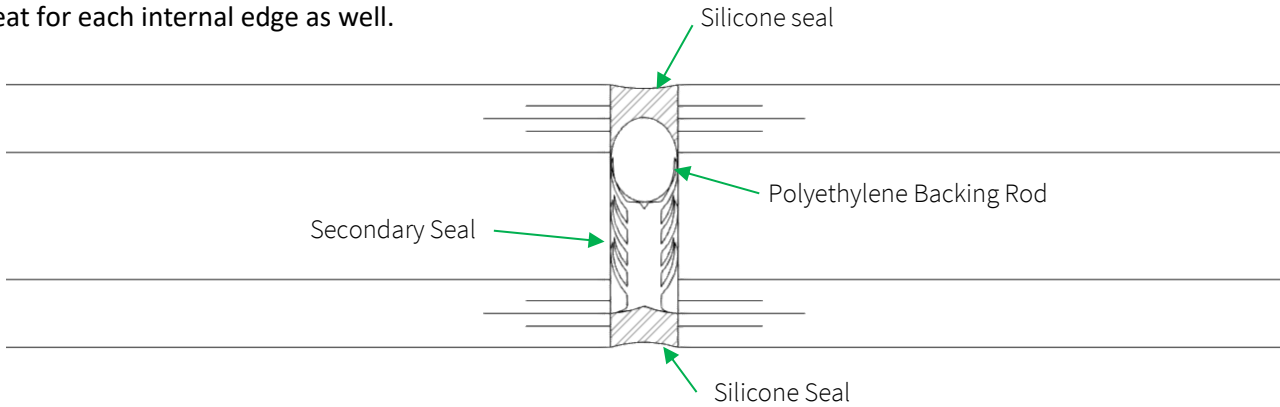

Figure 23 – Back-to-back glazed unit joining

Step 14

Finally, fill the drainage holes at the top of the fall with silicone before fitting the drainage hole covers to prevent water entering the unit. Insert the drainage hole covers into the drainage holes located at opposite ends of the back-to-back.

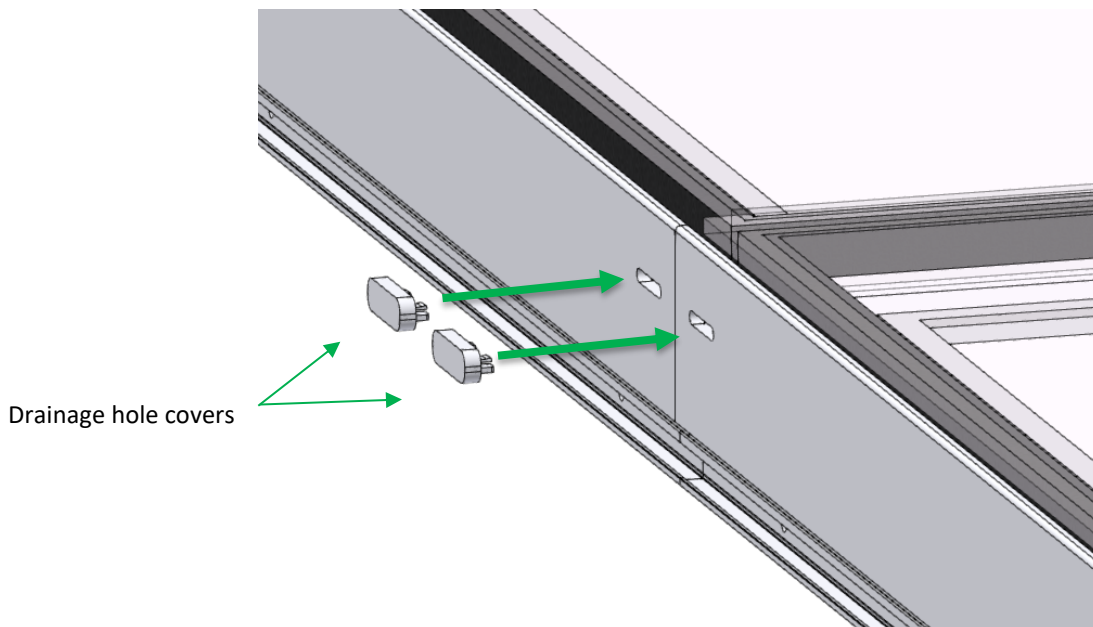

Figure 24 – Drainage hole cover installation

The edges of the frames should sit flush and should not require any finishing. If for whatever reason they do require external finishing, the appropriate colour of silicone to match the framework can be run along the joint.



Once installation has been completed take **photographs of the finished installation**. These must be retained for future reference.

Installation Checks

When the product has been sealed and fixed to the curb ensure the internal bubble gasket is sealing between the underside of the glass and top of the curb around the curb perimeter. This can be checked by trying to insert a piece of paper either side of the bubble gasket. If the paper can be inserted the gasket is not sealing and there could be a chance of cold bridging and therefore must be rectified. Gaps can be caused if the top of the curb is not straight or flat.

Interior Finishing

Glazing Vision does not specify the finishes permitted except for the following stipulations:

- The finish must be built up to the internal dimension of the product – see Glazing Vision’s sales drawings.
- No interior metal component (for example edging strips for plastering) may touch any part of the product framework.
- Any airspaces between the aluminium frame of the product and the internal finishes must be filled with insulating material.
- Nothing should be fixed directly to the product.



Contravention of any of these stipulations may severely undermine the thermal efficiency of the product.