

Section A-A (Scale 1:10)

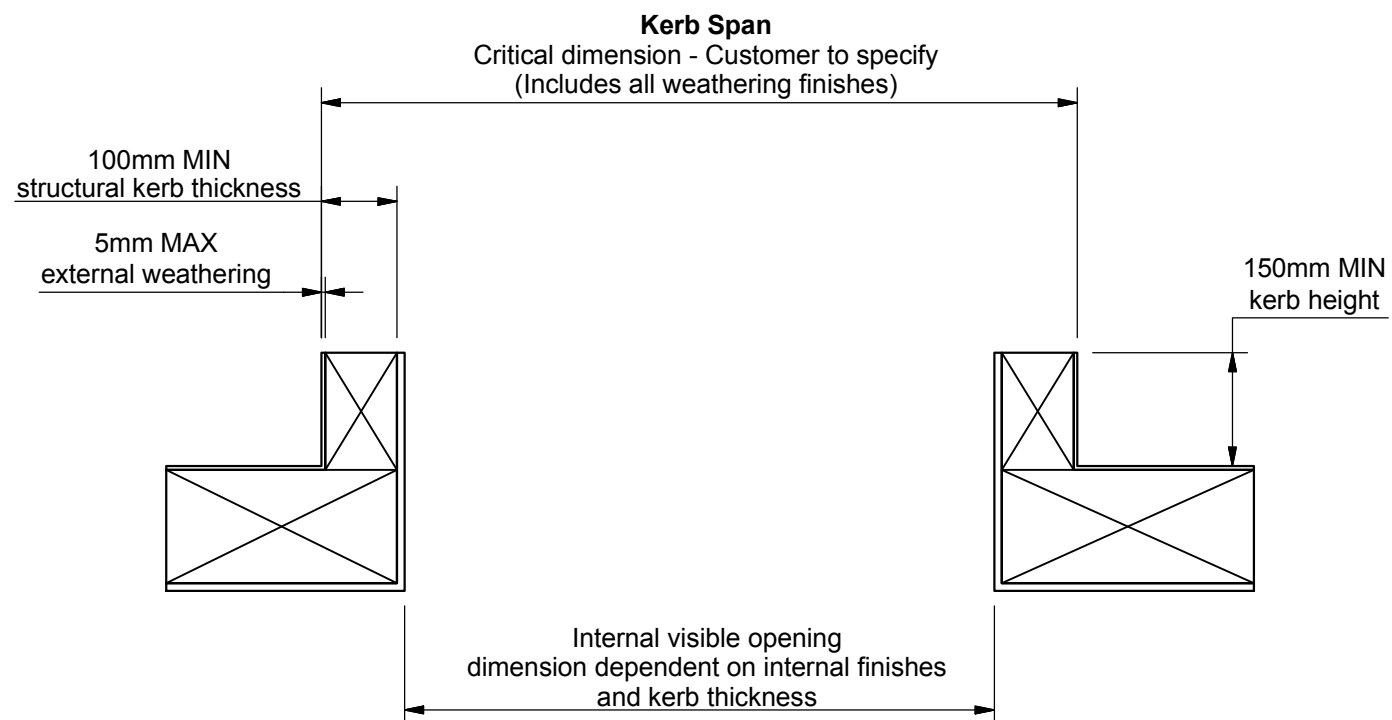

Section B-B (Scale 1:10)

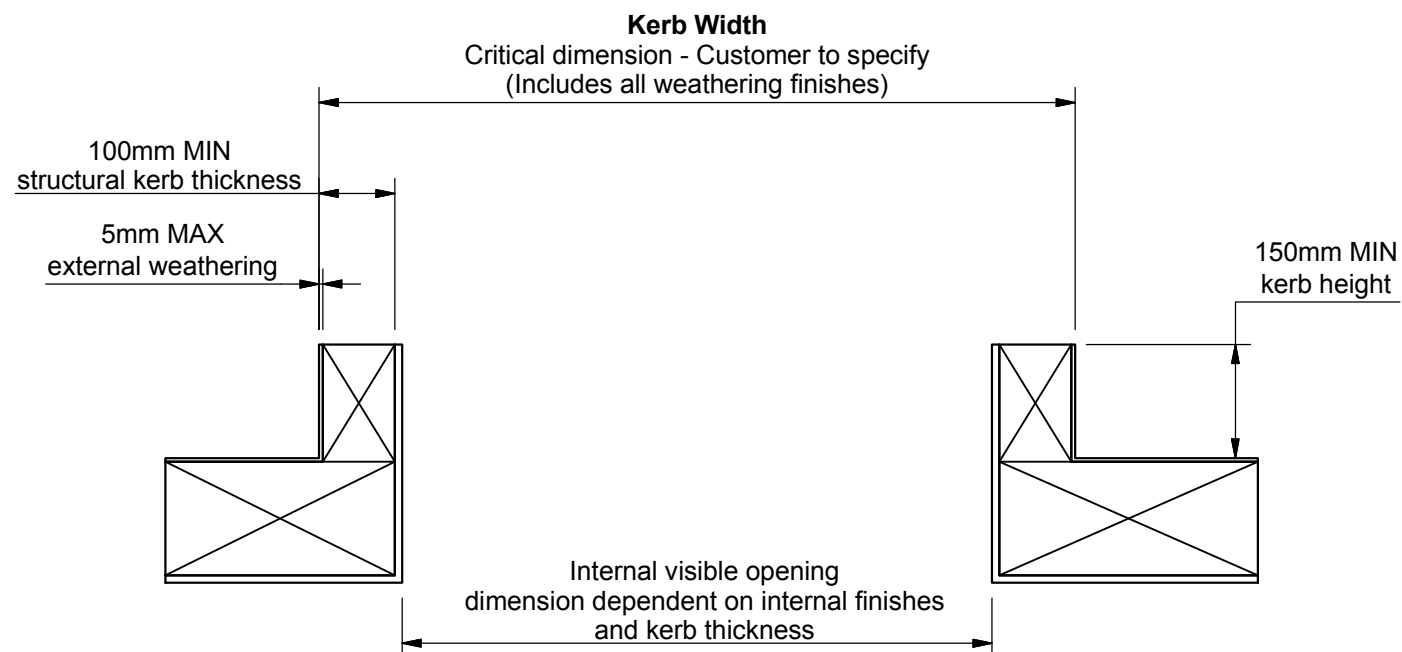

Detail C (Scale 1 : 5)
Cable entry position
(only required with downlighter option)

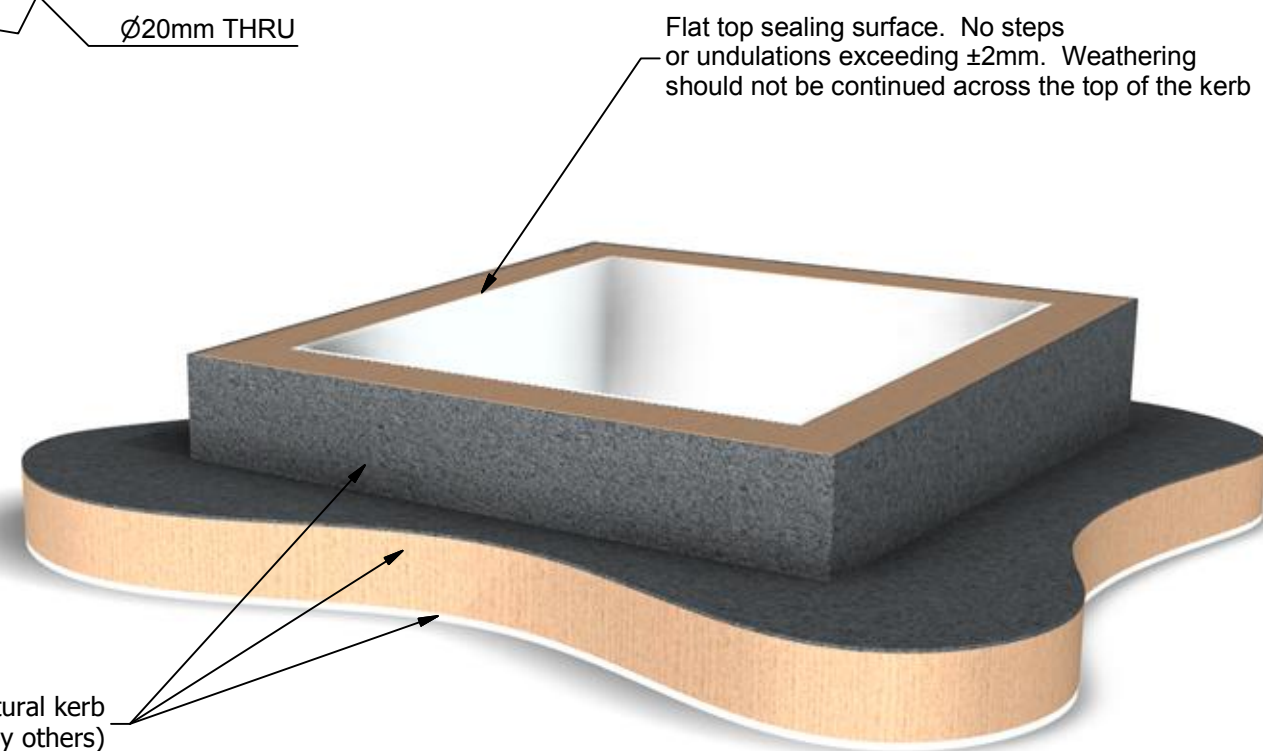
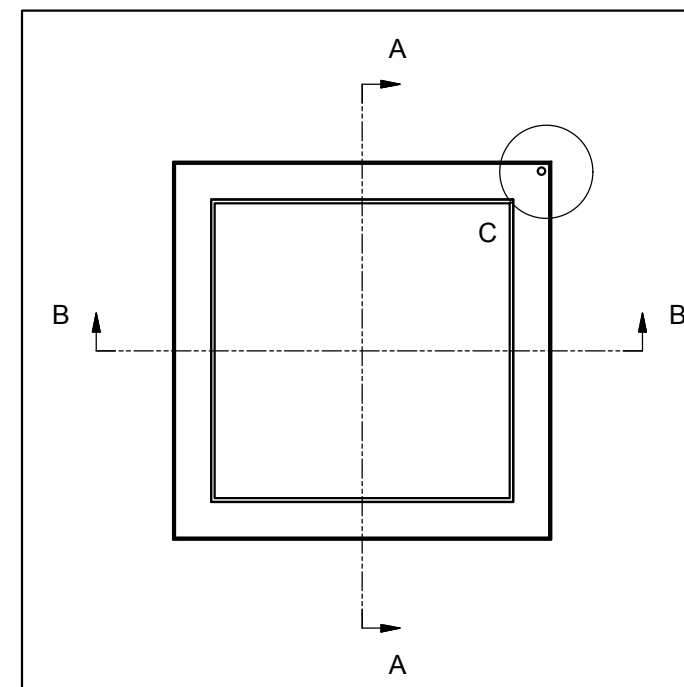
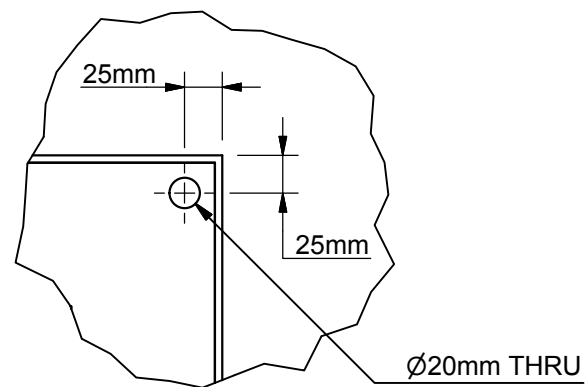

Rev	Revision Description	Drawn/Date
B	Cable exit hole position amended	DR 19.05.15
C	Kerb thickness updated	GH 16.08.16

Product: 404 - GV Standard Pyramid	Checked By: JWL
Description: Kerb detail	Check Date: 16.08.16
Materials: N/A	Drawn By: JWL
Finish: N/A	Drawn Date: 10.03.14
Weight: N/A	Quantity: N/A
Scale: 1:20 1:10 1:5	Drawing No: 404-ASS-402